

Lutron[®]

integration protocol

revision G 5 March 2011

Table of Contents

About Integration

Integration Operations	4
Operation Characters	4
Command Types	4
Command Structure	4
Command Termination	4
Command Examples	5
Integration Access Points	6
Command Rules and Formatting	6

Stanza

System Overview	7
Integration Access Points	8
System Commands	10

QS Standalone

System Overview	13
Integration Access Points	14
System Commands	16

RadioRA 2

System Overview	27
Integration Access Points	28
System Commands	30

Quantum

System Overview	33
Integration Access Points	34
System Commands	36

Devices

Stanza Keypads	47
Tabletop Stanza Keypads	49
Stanza Dimmers	53
Stanza Switch	55
Stanza Lamp Module	57
Stanza Input/Output Interface	59
GRAFIK Eye QS	61
Energi Savr Node QS / DALI	65
Energi Savr Node QS / Int'l 0-10V	69
Energi Savr Node QS / EcoSystem	73
Energi Savr Node QS / 0-10V	77
seeTouch Keypads	81
seeTouch QS International Keypads	84
Sivoia QS Shades	87
Sivoia QS Venetian Blinds	89
Maestro Dimmers	92
Hybrid Keypads	94
Tabletop seeTouch Keypads	98
Pico wireless controls	102
RadioRA 2 Visor Control Receiver	105
Radio Powr Savr	109

Programmer's Reference Appendix

Compatibility Matrix	111
Device Command Summary	112
Output Command Summary	113
Monitoring Command Summary	114
Error Command Summary	115

Lutron® integration protocol

Integration Operations

The *Lutron* integration protocol will allow third-party equipment, such as touch-screens, universal remote controls and software applications, to control and monitor devices in a *Lutron* light control system.

The protocol supports three basic types of integration operations:

- Execute an action in the *Lutron* system
- Query the status of the *Lutron* system and Lutron devices
- Monitor responses from the *Lutron* system

Operation Characters

To help create and manage the different integration operations, three distinct operation characters have been selected to begin each command. All protocol messages will start with one of the following operation characters:

- # Executes an action (e.g. turn a dimmer on/off)
- ? Query system information (e.g. determine on/off status of a dimmer)
- ~ Monitor responses from the system when requested or after a change has occurred (e.g. if someone turns on a dimmer locally a response command is sent out to indicate the change)

Note to Integrator: *Operation characters are not used in any other location in the protocol command string. Therefore, the driver can search for these characters to determine the start of a new command string.*

Command Types

Operation characters will be followed by command types. The two most common commands are: OUTPUT and DEVICE. Other command types are available; see the appendix for a summary.

- OUTPUT allows control and monitoring of device outputs such as dimmers and contact closure outputs.
- DEVICE allows control and monitoring of device inputs such as button presses, releases, and contact closure inputs.

Command Structure

The protocol command structure is made up of three parts:

Command	Integration ID	Command-specific fields
---------	----------------	-------------------------

1. The **Command** is made up of the operation character and the command type.
2. The **Integration ID** is assigned to each device in the system during system setup, providing a unique user-assigned address for each system device.
3. The **Command-specific fields** contain additional information relevant to the type of command. Details about what command-specific field data is supported can be found in the appropriate device specific section of this integration protocol guide.

Command Termination

Each command is made up of fields, separated by commas and terminated with a carriage return (ASCII dec 13/hex 0D) and a line feed (ASCII dec 10/hex 0A). Carriage return is shown as <CR> throughout this document and line feed is shown as <LF>.

Lutron® integration protocol

Command Examples

- 1) This command sets a dimmer (1) level to 75% with a 1 minute and 30 second fade time.

#OUTPUT,1,1,75,01:30<CR><LF>

Command	Integration ID	Command-specific fields		
		Action Number	Level	Fade Time
#OUTPUT	1	1	75	01:30

- 2) This command presses button number 1 of a keypad (2).

#DEVICE,2,4,3<CR><LF>

Command	Integration ID	Command-specific fields	
		Component Number	Action Number
#DEVICE	2	4	3

- 3) This command requests the output level for a dimmer (3).

?OUTPUT,3,1<CR><LF>

Command	Integration ID	Command-specific fields	
		Action	
?OUTPUT	3	1	

- 4) When a user makes a change to a dimmer locally, the following command response would be sent out from the system or when requested by the command in Example 3 above. This command response example shows the local dimmer (3) level was changed to 90%.

~OUTPUT,3,1,90.00<CR><LF>

Command	Integration ID	Command-specific fields	
		Action	Level
~OUTPUT	3	1	90.00

Lutron® integration protocol

Integration Access Points

- Integration Access Points communicate with external systems using RS232, Ethernet or both. The *Lutron* integration protocol will allow third-party equipment, such as touch-screens, keypads and software applications, to control and monitor devices in the *Lutron* lighting control system through an Integration Access Point. For more information, check the page specific to the Integration Access Point being used. An example of an Integration Access Point is the Stanza® Programming Control Interface (SZ-CI-PRG). For a listing of all the available Integration Access Points supported by a particular system, see the Integration Access Points section for that system in the table of contents.

Command Rules and Formatting

- All commands are in ASCII characters
- Each command is made up of fields, separated by commas and terminated with a carriage return (<CR>, ASCII 13) and a new line (<LF>, ASCII 10)
- Letter case is ignored
- Spaces are ignored
- Leading zeros are ignored

Lutron® integration protocol

Stanza® - System Overview

Stanza is a wireless single-room control system for lights and shades. The system is made up of dimmers, keypads, and other devices. Lutron's proven, patented RF technology ensures reliable performance. With the *Stanza* system, you can: create the right ambiance for varied activities, easily control your lights, reduce energy usage, and increase safety in and around your room.

Stanza System Device Compatibility Index:

	<i>Stanza</i>
<i>Stanza</i> Keypad	✓
Tabletop <i>Stanza</i> Keypad	✓
<i>Stanza</i> Dimmer	✓
<i>Stanza</i> Switch	✓
<i>Stanza</i> Lamp Module	✓
<i>Stanza</i> Input/Output Interface	✓
<i>Stanza</i> Plug-In Module	✓

Stanza® Integration Access Points

Programming Control Interface

Model: SZ-CI-PRG

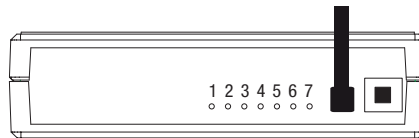
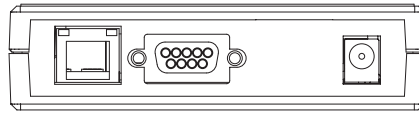

Why Integrate with the *Stanza* Programming Control Interface?

- Integrates a *Stanza* lighting control system with a PC or other digital equipment that supports RS232 or Ethernet TCP/IP communication
- Allows monitoring and control of system devices. For example, the SZ-CI-PRG can be used to simulate button presses, report button presses, monitor LEDs, and control light levels of dimmers.

Integration Capabilities

- 100 phantom “virtual” programmable buttons with LEDs (use DEVICE command)
- Monitoring of changes to other system devices (use MONITORING command)

Supported Command Types

- **DEVICE** allows control and monitoring of device inputs such as button presses and releases
- **MONITORING** commands are used to configure what types of messages the system will report



Stanza® Integration Access Points (*continued*)

Connection Information

Provides an RS232 and Ethernet connection to communicate with external equipment.

RS232

The RS232 connection has the following communication settings:

- Baud Rate 9600
- 8 data bits
- No parity bit
- 1 stop bit
- No flow control.

Ethernet

Configuring the control interface to communicate over a network takes not only knowledge of the *Stanza* system, but of networking as well. Installers with limited networking knowledge are advised to contact a networking professional before attempting to connect a control interface through a network. The information below will help an installer communicate the control interface configurations to a network professional.

The installer will make any necessary changes to the control interface using the Lutron® DeviceIP or *Stanza* PC software tool and the network professional can make any necessary changes to the networking equipment.

Single Ethernet Port

- IEEE® 802.3 Auto-Sensing 10BaseT / 100BaseTX
- Supports MDI/MDIX auto-crossover (no crossover cable needed).
- Female 8P8C “Computer RJ-45” socket
- Green Connect LED, Amber Activity LED
- Use Cat 5 cabling or better

TCP / IP Settings

- DHCP (dynamic) or static configuration <factory default = STATIC>
- IP Address: <static default = 192.168.1.50 or dynamic configuration>
- Subnet Mask: < static default = 255.255.255.0 or dynamic configuration >
- Gateway: <static default = 0.0.0.0 or dynamic configuration>
- NetBIOS Name: <factory default = LUTRON>
- NetBIOS Name is case sensitive

Protocols Used for Integration

- TELNET

Telnet Server

- Used by software and/or third party equipment (i.e. touch screen)
- Limited to transferring ASCII characters
- Telnet Port number is 23, can be changed using the *Lutron* DeviceIP software
- **Login:** lutron
- **Password:** integration

UDP Multicast Messaging

- Used by the *Stanza* PC software during device configuration and system programming
- There are no user modifiable settings for UDP messaging



Stanza® System Commands

SZ-CI-PRG: DEVICE Commands

DEVICE Command Format

^{Operation}
^{Integration ID (example)}
#DEVICE, 4, Component Number, Action Number, Parameters
_{Command} Use "DEVICE Command-specific fields" tables
 to complete these command fields.

DEVICE Command-specific fields

Component Number:

Component	Component Number	Available Actions
Button 1–100	2-101	Press
LED 1–100	102-201	Set (#) or Get (?) LED state
		NOTE: Set is for LEDs on unprogrammed buttons only

Action Numbers and Parameters:

Action	Action Number	Parameters
Press	3	None
Set (#) or Get (?) LED State	9	0=Off 1=On
* Set not allowed for programmed LEDs		

Example DEVICE Messages

Examples presume programming control interface has been assigned Integration ID 4.

Operation	Command String
Execute: #DEVICE, Integration ID, Component Number, Action Number, Parameter	
Press Button 1.	#DEVICE,4,2,3<CR><LF>
Turn on LED 1.	#DEVICE,4,102,9,1<CR><LF>
Response: ~DEVICE, Integration ID, Component Number, Action Number, Parameters	
LED 1 is on.	~DEVICE,4,102,9,1<CR><LF>



Stanza® System Commands (continued)

SZ-CI-PRG: MONITORING Commands

MONITORING Command Formats

Operation

#MONITORING, Monitoring Type, Action Number

Command

Use "MONITORING Command-specific fields" tables to complete these command fields.

MONITORING Command-specific fields

Monitoring Type:

Description	Monitoring Type
Diagnostic Monitoring	1
Button Monitoring	3
LED State Monitoring	4
Zone Level Monitoring	5
Reply State (if disabled, all messages FROM the integration access point will cease)	11
Prompt State (if disabled, the prompt will not be printed to the terminal)	12
Set (#) or Get (?) State of All Monitoring (except Reply and Prompt)	255

Action Numbers:

Action	Action Number
Enable	1
Disable	2

Example MONITORING Messages

Operation	Command String
Execute: #MONITORING, Monitoring Type, Action Number	
Disable Diagnostic Monitoring.	#MONITORING,1,2<CR><LF>
Enable Button Monitoring.	#MONITORING,3,1<CR><LF>
Query: ?MONITORING, Monitoring Type	
Is Diagnostic Monitoring disabled?	?MONITORING,1<CR><LF>
Response: ~MONITORING, Monitoring Type, Action Number	
Diagnostic Monitoring is disabled.	~MONITORING,1,2<CR><LF>

QS Standalone - System Overview

The QS family of products delivers scalable lighting and shading solutions for residential and commercial applications. At the center of the QS system are the GRAFIK Eye® QS control units, Energi Savr Node™ control units, and Sivoia® QS shades and drapes, providing direct control of electric and natural light. QS system devices communicate over the highly flexible QS link – the link allows for daisy-chain or t-tap wiring configurations. All QS system devices communicate without the need for interfaces, and addressing is automatic, eliminating the need to set DIP switches. In addition, QS keypads are configurable in the field to control lights, shades, lights + shades, or third-party devices. The QS system can easily be integrated with other systems through contact-closure input/output, DMX output, or Ethernet/RS232.

QS System Device Compatibility Index:

	QS Standalone
<i>GRAFIK Eye QS</i>	✓
<i>seeTouch® QS</i>	✓
<i>Sivoia QS Shade</i>	✓
<i>Energi Savr Node QS / DALI</i>	✓
<i>Energi Savr Node QS / Int'l 0-10V</i>	✓
<i>Energi Savr Node QS / EcoSystem®</i>	✓
<i>Energi Savr Node QS / 0-10V</i>	✓



QS Standalone Integration Access Points

Network Interface

Model: QSE-CI-NWK-E

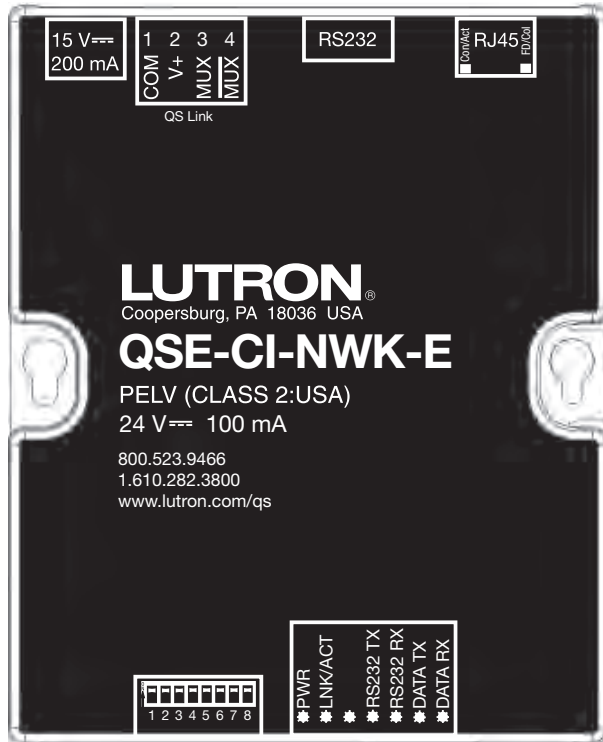

Why Integrate with a QSE-CI-NWK-E?

- Integrates a QS lighting control system with a PC or other digital equipment that supports RS232 or Ethernet TCP/IP connection
- Allows monitor and control of system devices. For example, the QSE-CI-NWK-E can be used to simulate button presses, report button presses, control light levels, and monitor light levels.

Additional Commands

- **MONITORING** specifies what type of messages the system will report
- **ETHERNET** modifies the Ethernet configurations of the QSE-CI-NWK-E
- **RESET** restarts the QSE-CI-NWK-E or restores it to factory defaults
- **INTEGRATION ID** assigns IDs to devices, so that they may be referred to in a more logical fashion
- **DETAILS** returns information about a QS device
- **ERROR** reports syntax errors in an integration string command or query
- **PROGRAMMING** allows user to program Phantom Buttons on the NWK supported in version 8.0 or higher
- **DEVICE** used to activate Phantom Buttons on the NWK



QS Standalone Integration Access Points (cont.)

Connection Information

Provides an RS232 and Ethernet connection to communicate with external equipment. Communication is through either RS232 or Ethernet, but not both simultaneously.

RS232

The RS232 connection has the following communication settings:

- Baud Rate 9600/19200/38400/115200 (set via dipswitch on unit)
- 8 data bits
- No parity bit
- 1 stop bit
- No flow control.

Ethernet

Configuring the control interface to communicate over a network takes not only knowledge of the QS system, but of networking as well. Installers with limited networking knowledge are advised to contact a networking professional before attempting to connect a QSE-CI-NWK-E through a network. The information below will help an installer communicate the QSE-CI-NWK-E configurations to a network professional.

The installer will make any necessary changes to the control interface using the Lutron® DeviceIP or PC software tool and the network professional can make any necessary changes to the networking equipment.

Single Ethernet Port

- IEEE® 802.3 Auto-Sensing 10BaseT / 100BaseTX
- Supports MDI/MDIX auto-crossover (no crossover cable needed).
- Female 8P8C “Computer RJ-45” socket
- Green Connect LED, Amber Activity LED
- Use Cat 5 cabling or better

TCP / IP Settings

- IP Address: <static default = 192.168.250.1>
- Subnet Mask: < static default = 255.255.255.0>
- Gateway: <static default = 0.0.0.0>

Protocols Used for Integration

- TELNET

Telnet Server

- Used by third party equipment (i.e. touch screen)
- Limited to transferring ASCII characters
- Telnet Port number is 23
- Login #1: nwk
- Login #2: nwk2



QS Standalone System Commands

QSE-CI-NWK-E: MONITORING Commands

MONITORING Command Formats

Operation

#MONITORING, Monitoring Type, Action Number

Command

Use "MONITORING Command-specific fields" tables to complete these command fields.

MONITORING Command-specific fields

- Monitoring Type:**

Description	Monitoring Type
Diagnostic Monitoring	1
Event Monitoring	2
Button Monitoring	3
Zone Monitoring	5
Scene #	8
Reply State (if disabled, all messages FROM the integration access point will cease)	11
Prompt State (if disabled, the prompt will not be printed to the terminal)	12
Set or Get State of All Monitoring (except Reply and Prompt)	255

- Action Numbers:**

Action	Action Number
Enable	1
Disable	2

Example MONITORING Commands

Operation	Command String
Execute: #MONITORING, Monitoring Type, Action Number	
Disable Diagnostic Monitoring.	#MONITORING,1,2<CR><LF>
Enable Zone Monitoring.	#MONITORING,5,1<CR><LF>
Query: ?MONITORING, Monitoring Type	
Is Button Monitoring disabled?	?MONITORING,3<CR><LF>
Response: ~MONITORING, Monitoring Type, Action Number	
Button Monitoring is enabled.	~MONITORING,3,1<CR><LF>



QS Standalone System Commands (continued)

QSE-CI-NWK-E: ETHERNET Commands

ETHERNET Command Formats

Operation

#ETHERNET, Configuration Number, Parameters

Command

Use "ETHERNET Command-specific fields" tables to complete these command fields.

ETHERNET Command-specific fields

- **Configuration Number**

Description	Config. Number	Parameters
Set IP Address	0	Address (XXX.XXX.XXX.XXX)
Set Gateway Address	1	Address (XXX.XXX.XXX.XXX)
Set Subnet Mask	2	Address (XXX.XXX.XXX.XXX)
Change Login Info	3	User (1 or 2), Old Login, New Login

Example ETHERNET Commands

Operation	Command String
Execute: #ETHERNET, Configuration Number, Parameters	
Set IP Address to 192.168.250.1	#ETHERNET,0,192.168.250.1<CR><LF>
Set Gateway Address to 10.2.4.1	#ETHERNET,1,10.2.4.1<CR><LF>
Query: ?ETHERNET, Configuration Number, Parameters	
What is the IP Address?	?ETHERNET,0<CR><LF>
What is the Login Information for user 1?	?ETHERNET,3,1<CR><LF>
What is the Login Information for ALL users? (Note: 0 = ALL)	?ETHERNET,3,0<CR><LF>
Response: ~DEVICE, Integration ID, Configuration Number, Parameters	
The IP Address is 192.168.250.1	~ETHERNET,0=,192.168.250.1<CR><LF>



QS Standalone System Commands *(continued)*

QSE-CI-NWK-E: INTEGRATION ID Commands

INTEGRATION ID Command Formats

Operation

#INTEGRATIONID, Action Number, Parameters

Command

Use "INTEGRATIONID" Command-specific fields tables to complete these command fields.

INTEGRATION ID Command-specific fields

- Actions

Description	Action #	Parameters
Set or Get Integration ID for a Serial Number	1	Serial Number = 8 character HEX serial number of the device, Integration ID = The integration ID to be assigned.
Change Integration ID	2	Current Integration ID, New Integration ID NOTE: An error will be reported if the new Integration ID is the same as an existing Integration ID in the system.
Get Info from ID	3	Integration ID NOTE: If this field is left blank, all integration IDs will be printed.
Set or Get output Integration ID	4	Serial Number, Component Number, Integration ID

Example INTEGRATION ID Commands

Operation	Command String
Execute: #INTEGRATIONID, Integration ID, Action Number, Parameters	
Set the Integration ID for a serial number	#INTEGRATIONID,1,1234ABCD,kitchen dimmer<CR><LF>
Response: ~INTEGRATIONID, Integration ID, Action Number, Parameters	
Set the Integration ID for a serial number	~INTEGRATIONID,1,1234ABCD,kitchen dimmer<CR><LF>
Execute: ?INTEGRATIONID, Integration ID, Action Number, Parameters	
Get the Integration ID for a serial number	?INTEGRATIONID,1,5678EFEF<CR><LF>
Response: ~INTEGRATIONID, Integration ID, Action Number, Parameters	
Get the Integration ID for a serial number	~INTEGRATIONID,1,5678EFEF,living room keypad<CR><LF>
Execute: #INTEGRATIONID, Integration ID, Action Number, Parameters	
Change the Integration ID	#INTEGRATIONID,2,diningroomlights1,diningroomaccents<CR><LF>
Response: ~INTEGRATIONID, Integration ID, Action Number, Parameters	
Change the Integration ID	~INTEGRATIONID,2,diningroomlights1,diningroomaccents<CR><LF>
Execute: ?INTEGRATIONID, Integration ID, Action Number, Parameters	
Get information about an Integration ID command	?INTEGRATIONID,3,livingroomkeypad<CR><LF>
Response: ~INTEGRATIONID, Integration ID, Action Number, Parameters	
Get information about an Integration ID command	~INTEGRATIONID,3,livingroomkeypad,DEVICE,5678EFEF<CR><LF>



QS Standalone System Commands *(continued)*

QSE-CI-NWK-E: DETAILS String

DETAILS Command Formats

Operation
 ?DETAILS, ID¹
Command

Example DETAILS String

Operation	Command String
Query: ?DETAILS, ID	
Get details of the device with serial ID number 00AC123D	?DETAILS,00AC123D<CR><LF>
Response: ~DETAILS, Serial Number, Name, Family, Model, Software Rev., Boot Software Rev.	
The device with serial ID number 00AC123D has the following information: Name = GRAFIK Eye 1 Product Family = GRAFIK Eye Product Model = QSG Software Revision = 1.70 Boot Code Software Revision = 2	~DETAILS,SN:00AC123D,IntegrationID:GRAFIK Eye1,Family:GRAFIK_Eye(2),Product:QSG(1),CODE:1.70,Boot:2.1,HW:1.1<CR><LF>

NOTE

1. Device ID may be entered as the serial ID number or the Integration ID. Use ALL_DEVICES or FFFFFFFF to query all devices on the link.

QS
 Standalone



QS Standalone System Commands *(continued)*

QSE-CI-NWK-E: RESET Commands

RESET Command Formats

Operation

#RESET, Action Number

Command

Use "RESET Command-specific fields" tables to complete these command fields.

RESET Command-specific fields

- Action Numbers:

Action	Action Number
Restart the device	0
Restore to factory defaults	1

Example RESET Commands

Operation	Command String
Execute: #RESET, Action Number	
Restart the NWK	#RESET,0<CR><LF>
Restore NWK to factory defaults	#RESET,1<CR><LF>



QS Standalone System Commands *(continued)*

QSE-CI-NWK-E: PROGRAMMING Commands

PROGRAMMING Command Formats

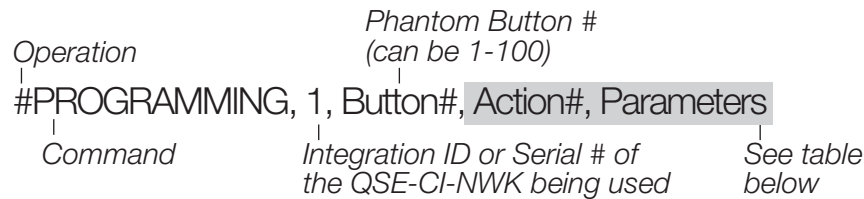

PROGRAMMING Command-specific fields

- Programming Type:

Description	Action #	Parameters
Add programming to a phantom button (Shade level only)	1	a) Shade Integration ID – The Integration ID of the shade being programmed b) Shade Component # – Always '0' c) Level – The level to which the shade being programmed will go to on activation of this button
Clear programming from a phantom button. NOTE: Use button #0 to clear programming from all buttons.	3	None
Configure Stop-If-Moving functionality NOTE: Use button #0 to configure Stop-If-Moving functionality on all buttons.	4	0 = Stop-If-Moving OFF 1 = Stop-If-Moving ON
Add programming to a phantom button (Venetian blind, lift & tilt levels)	5	a) Venetian Integration ID b) Component Number (always 0) c) Lift level d) Tilt level
Add programming to a phantom button (Venetian blind, tilt only)	6	a) Venetian Integration ID b) Component Number (always 0) c) Tilt level
Add programming to a phantom button (Venetian blind, lift only)	7	a) Venetian Integration ID b) Component Number (always 0) c) Lift level



QS Standalone System Commands *(continued)*

QSE-CI-NWK-E: PROGRAMMING Commands

PROGRAMMING Command Formats

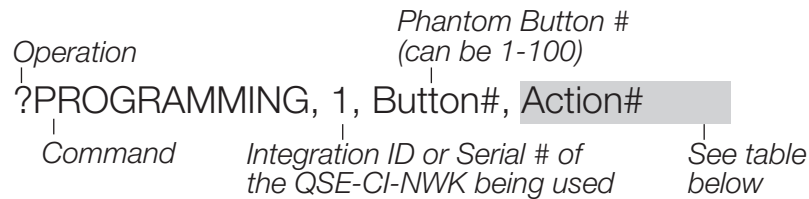

PROGRAMMING Command-specific fields

- Configuration Number**

Description	Action #	Parameters
Display programming of a specific phantom button NOTE: To display programming of all phantom buttons, leave the button # field blank	None	None
Display Stop-If-Moving configuration of a specific phantom button NOTE: To display Stop-If-Moving configuration of all phantom buttons, use button #0	4	None

Example PROGRAMMING Commands

The following examples show how to verify the programming of the phantom buttons of a QSE-CI-NWK-E with an Integration ID of "1".

Operation	Command String
Display programming of phantom button 1	?PROGRAMMING,1,1<CR><LF>
Display programming of all phantom buttons	?PROGRAMMING,1<CR><LF>
Display Stop-If-Moving configuration of phantom button 5	?PROGRAMMING,1,5,4<CR><LF>
Display Stop-If-Moving configuration of all phantom buttons	?PROGRAMMING,1,0,4<CR><LF>

QS
 Standalone



QS Standalone System Commands *(continued)*

QSE-CI-NWK-E: DEVICE Commands

DEVICE Command Formats

<i>Operation</i>	<i>Phantom Button # (can be 1-100)</i>
#DEVICE, 1, Button#, Action#, Parameters	
<i>Command</i>	<i>Integration ID or Serial # of the QSE-CI-NWK being used</i>
	<i>See table below</i>

DEVICE Command-specific fields

- Actions**

Description	Action #	Parameters
Activate the phantom button preset	3	None
Set a custom level of the shades programmed to the phantom button	14 ¹	Level - The level the shades will go to ¹
Raise the shades and venetians	18 ²	None
Lower the shades and venetians	19 ²	None
Stop the shades and venetians	20	None
Set a custom lift and tilt level of venetian blinds programmed to the phantom button	23 ¹	Lift level % Tilt level %
Set a custom lift level only of venetian blinds programmed to the phantom button	24 ¹	Lift level %
Set a custom tilt level only of venetian blinds programmed to the phantom button	25 ¹	Tilt level %

NOTES

- Specifying a custom level above will not affect the preset level programmed for the phantom button.
- For Venetian blinds, the Raise & Lower Actions will affect either the lift or the tilt based on how the phantom button was programmed. If #PROGRAMMING Action 5 is used (affecting both lift and tilt levels), then the Raise & Lower Actions will affect the tilt.

NOTE: Programming and device commands require version 8.0 or higher of the NWK software.

Example DEVICE Commands

The following examples show how we can activate phantom buttons on a link with a QSE-CI-NWK-E whose Integration ID is "1".

Operation	Command String
Activate Preset on phantom button 1	#DEVICE,1,1,3<CR> <LF>
Set the level of all shades programmed to phantom button 2 to 50%	#DEVICE,1,2,14,50<CR><LF>
Set all venetian blinds programmed to phantom button 3 to a lift level of 50% and tilt level of 25%	#DEVICE,1,3,23,50,25<CR><LF>
Set all venetian blinds programmed to phantom button 4 to a lift level of 50%	#DEVICE,1,4,24,50<CR><LF>
Set all venetian blinds programmed to phantom button 5 to a tilt level of 25%	#DEVICE,1,5,25,25<CR><LF>
Raise the shades and venetian blinds programmed to phantom button 6	#DEVICE,1,6,18<CR><LF>
Lower shades and venetian blinds programmed to phantom button 7	#DEVICE,1,7,19<CR><LF>
Stop shades and venetian blinds programmed to phantom button 8	#DEVICE,1,8,20<CR><LF>



QS Standalone System Commands *(continued)*

QSE-CI-NWK-E: ERROR Response Strings

ERROR Command Formats

Operation

~ERROR, Error Number

Command

Use "ERROR Command-specific fields" tables to complete this field.

ERROR Command-specific fields

Error Number:

Description	Error Number
Parameter count mismatch	1
Object does not exist	2
Invalid action number	3
Parameter data out of range	4
Parameter data malformed	5

Example ERROR Messages

Operation	Command String
Parameter count mismatch: Too many or too few parameters for the specified action	
Too many parameters when activating scene	#AREA,2,6,1,1,1,1,1<CR><LF>
Parameter count mismatch.	~ERROR,1<CR><LF>
Object does not exist: The Integration ID or serial number entered does not map to a known part of the system	
Send command to an ID that is not valid	#OUTPUT,1234,1,100.00<CR><LF>
Object does not exist	~ERROR,2<CR><LF>
Invalid Action: The action does not exist for this command	
Send invalid action (4321) to Area 2.	#AREA,2,4321<CR><LF>
Invalid action number	~ERROR,3<CR><LF>
Parameter data out of range: The parameter data is out of range for this action	
Send Output 11 to 120%.	#OUTPUT,11,1,120.00<CR><LF>
Parameter data out of range	~ERROR,4<CR><LF>
Parameter data malformed: The parameter data given was not formatted properly	
Set Time to 12:23:24:25	#SYSTEM,1,12:23:24:25<CR><LF>
Invalid action number	~ERROR,5<CR><LF>

Lutron® integration protocol

RadioRA® 2 - System Overview

RadioRA 2 is a wireless multi-room control system for lights and shades. The system is made up of repeaters, dimmers, keypads, and other devices. Lutron's proven, patented RF technology ensures reliable performance. With the *RadioRA 2* system, you can: create the right ambiance for varied activities, easily monitor and control your lights, reduce energy usage, and increase safety in and around your home.

RadioRA 2 System Device Compatibility Index:

	<i>RadioRA 2</i>
Maestro® Dimmer	✓
Tabletop seeTouch® Keypad	✓
Visor Control Receiver	✓
GRAFIK Eye® QS	✓
<i>seeTouch RadioRA 2</i>	✓
Sivoia® QS RF Shades	✓
<i>GRAFIK Eye QS</i>	✓
Hybrid Keypad	✓
Pico® Wireless Controls	✓
Radio Powr Savr™	✓

RadioRA® 2 Integration Access Points

Main Repeater

Model: RR-MAIN-REP-WH

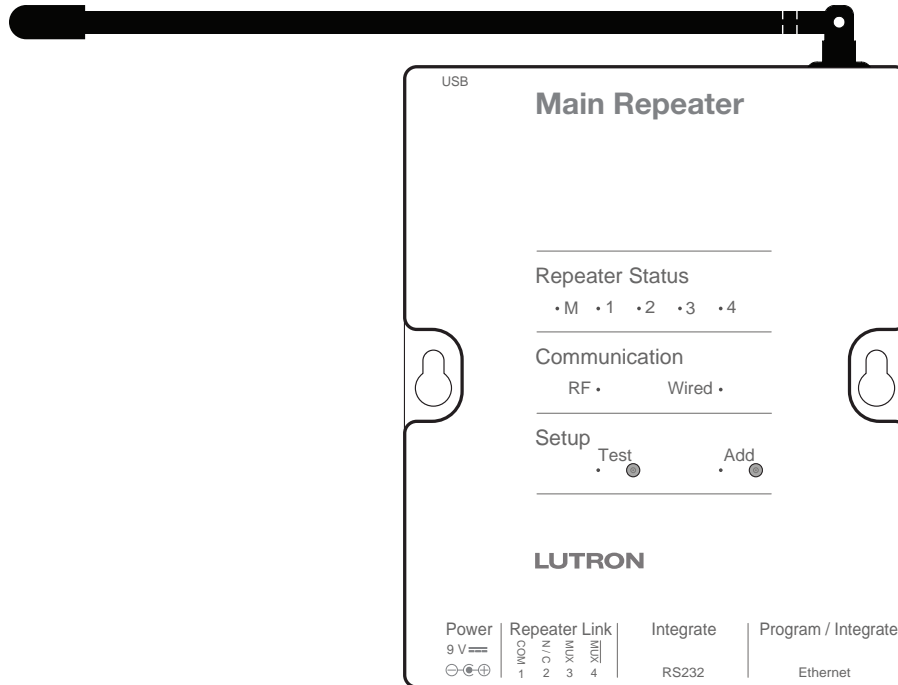

Why Integrate with the RadioRA® 2 Main Repeater?

- Integrates a *RadioRA 2* lighting control system with a PC or other digital equipment that supports RS232 or Ethernet TCP/IP communication.
- Allows monitoring and control of system devices. For example, the Main Repeater can be used to simulate button presses, report button presses, monitor LEDs, and control light levels of dimmers.

Integration Capabilities

- 100 “virtual” programmable buttons with LEDs (use DEVICE command)
- Monitoring of changes to other system devices (use MONITORING command)

Additional Commands

- **MONITORING** commands are used to program what types of messages the system will report

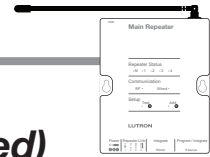

RadioRA® 2 Integration Access Points (continued)

Connection Information

Provides an RS232 and Ethernet connection to communicate with external equipment.

RS232

The RS232 connection has the following communication settings:

- Baud Rate 9600
- 8 data bits
- No parity bit
- 1 stop bit
- No flow control

Ethernet

Configuring the control interface to communicate over a network takes not only knowledge of the *RadioRA 2* system, but of networking as well. Installers with limited networking knowledge are advised to contact a networking professional before attempting to connect a control interface through a network. The information below will help an installer communicate the control interface configurations to a network professional.

The installer will make any necessary changes to the control interface using the Lutron® DeviceIP or *RadioRA 2* PC software tool and the network professional can make any necessary changes to the networking equipment.

Single Ethernet Port

- IEEE® 802.3 Auto-Sensing 10BaseT / 100BaseTX
- Supports MDI/MDIX auto-crossover (no crossover cable needed).
- Female 8P8C “Computer RJ-45” socket
- Green Connect LED, Amber Activity LED
- Use Cat 5 cabling or better

TCP / IP Settings

- DHCP (dynamic) or static configuration <factory default = DHCP>
- IP Address: <static default = 192.168.1.50 or dynamic configuration>
- Subnet Mask: < static default = 255.255.255.0 or dynamic configuration >
- Gateway: <static default = 0.0.0.0 or dynamic configuration>

Protocols Used for Integration

- TELNET

Telnet Server

- Up to 4 telnet sessions can be accessed through Essentials Software
- Used by software and/or third party equipment (i.e. touch screen)
- Limited to transferring ASCII characters
- Telnet Port number is 23, can be changed using the *Lutron* DeviceIP software or *RadioRA 2* PC software
- **Login:** lutron
- **Password:** integration

Notes: -Up to four additional login and password values can be defined in the *RadioRA 2* PC Software.

-Only one connection per login/password is allowed at a time.

UDP Multicast Messaging

- Used by the *RadioRA 2* PC software during device configuration and system programming
- There are no user modifiable settings for UDP messaging

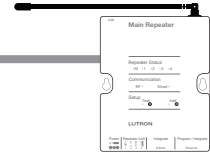

RadioRA® 2 System Commands

RR-MAIN-REP-WH: DEVICE Commands

DEVICE Command Formats

^{Operation}
^{Integration ID (example)}
#DEVICE, 1, Component Number, Action Number, Parameters
_{Command} *Use "DEVICE Command-specific fields" tables to complete these command fields.*

DEVICE Command-specific fields

- Component Number:**

Component	Component Number	Available Actions
Button 1–100	1-100	Press, Release
LED 1–100	101-200	Set or Get LED state

- Action Numbers and Parameters:**

Action	Action Number	Parameters
Press	3	None
Release	4	None
Set or Get LED State	9	0=Off 1=On

Example DEVICE Commands

Operation	Command String
Execute: #DEVICE, Integration ID, Component Number, Action Number, Parameters	
Press Button 1.	#DEVICE,4,1,3<CR><LF>
Release Button 1	#DEVICE,4,1,4<CR><LF>
Turn on LED 1.	#DEVICE,4,101,9<CR><LF>
Query: ?DEVICE, Integration ID, Component Number, Action Number	
What is the state of LED 1?	?DEVICE,4,101,9<CR><LF>
Response: ~DEVICE, Integration ID, Component Number, Action Number, Parameters	
LED 1 is on.	~DEVICE,4,101,9,1<CR><LF>

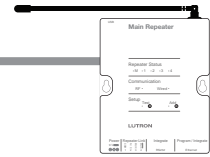

RadioRA® 2 System Commands *(continued)*

RR-MAIN-REP-WH: MONITORING Commands

MONITORING Command Formats

Operation

#MONITORING, Monitoring Type, Action Number

Command

Use "MONITORING Command-specific fields" tables to complete these command fields.

MONITORING Command-specific fields

- Monitoring Type:**

Description	Monitoring Type
Diagnostic Monitoring	1
Button Monitoring (if enabled, button actions will be reported)	3
LED Monitoring (if enabled, LED states will be reported)	4
Zone Monitoring (if enabled, zone levels will be reported, i.e. dimmer, shade, contact closure output level)	5
Reply State (if disabled, all messages FROM the integration access point will cease)	11
Prompt State (if disabled, the prompt will not be printed to the terminal)	12
Set or Get State of All Monitoring (except Reply and Prompt)	255

- Action Numbers:**

Action	Action Number
Enable	1
Disable	2

Example MONITORING Commands

Operation	Command String
Execute: #MONITORING, Monitoring Type, Action Number	
Disable Diagnostic Monitoring.	#MONITORING,1,2<CR><LF>
Enable Event Monitoring.	#MONITORING,2,1<CR><LF>
Query: ?MONITORING, Monitoring Type	
Is Diagnostic Monitoring disabled?	?MONITORING,1<CR><LF>
Response: ~MONITORING, Monitoring Type, Action Number	
Diagnostic Monitoring is disabled.	~MONITORING,1,2<CR><LF>

Lutron® integration protocol

Quantum® - System Overview

The *Quantum* System is Lutron's premier commercial light control system. It allows the control and monitor of individual devices and outputs as well as allowing control of entire areas, shade groups or other portions of the system. The *Quantum* System includes QS devices such as the GRAFIK Eye® QS and Sivoia® QS shades as well as Lutron's EcoSystem® Ballasts and GRAFIK Dimming panels. When integrating with a *Quantum* System the integrator gets additional access to portions of a the system not available when using products in stand-alone mode, particularly the ability to activate scenes on an area-by-area basis and to control the position of and activate presets on entire groups of shades at once.

Quantum System Device Compatibility Index:

	Quantum
GRAFIK Eye QS	✓
seeTouch® QS	✓
Sivoia QS Shade	✓
QS Input/Output Interface	✓
Energi Savr Node™ QS / DALI	✓
Energi Savr Node QS / Int'l 0-10V	✓
Energi Savr Node QS / EcoSystem	✓
Energi Savr Node QS / 0-10V	✓

Why Integrate with a Quantum System

- Compatible with *Quantum* System version 1.7 or higher
- Gain access to system only information
- Activate System Area scenes
- Set levels for System Outputs
- Activate System Shade Group presets
- View and modify parameters of a *Quantum* System, such as time, date, time zone, etc.

Command Types

Operation characters will be followed by command types.

- AREA allows control of an area in the *Quantum* System. Scenes can be activated, occupancy monitored etc.
- SHADEGRP allows control of shade groups in the *Quantum* System. Shade Groups are collections of shades that operate in unison
- OUTPUT allows control and monitoring of a *Quantum* System output group such as a lighting zone or closure output.
- SYSTEM allows setting and controlling system parameters and variables
- HELP displays usage information for the supported commands and their corresponding actions
- INTEGRATION ID allows querying integration IDs of devices in the system



Quantum® Integration Access Points

Network Interface

Model: QSE-CI-NWK-E



Why Integrate with a QSE-CI-NWK-E?

- Integrates a QS lighting control system with a PC or other digital equipment that supports RS232 or Ethernet TCP/IP connection
- Allows monitor and control of system devices. For example, the QSE-CI-NWK-E can be used to simulate button presses, report button presses, monitor LEDs, and control light levels.

Additional Commands

- **MONITORING** specifies what type of messages the system will report
- **ETHERNET** modifies the Ethernet configurations of the QSE-CI-NWK-E
- **RESET** restarts the QSE-CI-NWK-E or restores it to factory defaults
- **INTEGRATION ID** assigns IDs to devices, so that they may be referred to in a more logical fashion
- **DETAILS** returns information about a QS device
- **ERROR** reports syntax errors in an integration string command or query



Quantum® Integration Access Points (continued)

Connection Information

Provides an RS232 and Ethernet connection to communicate with external equipment.

RS232

The RS232 connection has the following communication settings:

- Baud Rate 9600/19200/38400/115200 (set via dipswitch on unit)
- 8 data bits
- No parity bit
- 1 stop bit
- No flow control.

Ethernet

Configuring the control interface to communicate over a network takes not only knowledge of the Quantum® system, but of networking as well. Installers with limited networking knowledge are advised to contact a networking professional before attempting to connect a QSE-CI-NWK-E through a network. The information below will help an installer communicate the QSE-CI-NWK-E configurations to a network professional.

The installer will make any necessary changes to the control interface using the Lutron® DeviceIP or *Quantum* PC software tool and the network professional can make any necessary changes to the networking equipment.

Single Ethernet Port

- IEEE® 802.3 Auto-Sensing 10BaseT / 100BaseTX
- Supports MDI/MDIX auto-crossover (no crossover cable needed).
- Female 8P8C “Computer RJ-45” socket
- Green Connect LED, Amber Activity LED
- Use Cat 5 cabling or better

TCP / IP Settings

- IP Address: <static default = 192.168.250.1>
- Subnet Mask: < static default = 255.255.255.0>
- Gateway: <static default = 0.0.0.0>

Protocols Used for Integration

- TELNET

Telnet Server

- Used by third party equipment (i.e. touch screen)
- Limited to transferring ASCII characters
- Telnet Port number is 23
- Login #1: nwk
- Login #2: nwk2



Quantum® System Commands

QSE-CI-NWK-E: MONITORING Commands

MONITORING Command Formats

Operation

#MONITORING, Monitoring Type, Action Number

Command

Use "MONITORING Command-specific fields" tables to complete these command fields.

MONITORING Command-specific fields

Monitoring Type:

Description	Monitoring Type
Diagnostic Monitoring	1
Event Monitoring	2
Button Monitoring	3
LED State Monitoring	4
Zone Level Monitoring	5
Occupancy Monitoring	6
Area Scene, Device Scene and Shade Group Preset Number Monitoring	8
Reply State (if disabled, all messages FROM the integration access point will cease)	11
Prompt State (if disabled, the prompt will not be printed to the terminal)	12

Action Numbers:

Action	Action Number
Enable	1
Disable	2

Example MONITORING Messages

Operation	Command String
Execute: #MONITORING, Monitoring Type, Action Number	
Disable Diagnostic Monitoring.	#MONITORING,1,2<CR><LF>
Enable Button Monitoring.	#MONITORING,5,1<CR><LF>
Query: ?MONITORING, Monitoring Type	
Is Button Monitoring enabled?	?MONITORING,3<CR><LF>
Response: ~MONITORING, Monitoring Type, Action Number	
Button Monitoring is enabled.	~MONITORING,3,1<CR><LF>



Quantum® System Commands (continued)

QSE-CI-NWK-E: ETHERNET Commands

ETHERNET Command Formats

Operation

#ETHERNET, Configuration Number, Parameters

Command

Use "ETHERNET Command-specific fields" tables to complete these command fields.

ETHERNET Command-specific fields

- **Configuration Number**

Description	Config. Number	Parameters
Set IP Address	0	Address (XXX.XXX.XXX.XXX)
Set Gateway Address	1	Address (XXX.XXX.XXX.XXX)
Set Subnet Mask	2	Address (XXX.XXX.XXX.XXX)
Change Login Info	3	User (1 or 2), Old Login, New Login

Example ETHERNET Commands

Operation	Command String
Execute: #ETHERNET, Configuration Number, Parameters	
Set IP Address to 192.168.250.1	#ETHERNET,0,192.168.250.1<CR><LF>
Set Gateway Address to 10.2.4.1	#ETHERNET,1,10.2.4.1<CR><LF>
Query: ?ETHERNET, Configuration Number, Parameters	
What is the IP Address?	?ETHERNET,0<CR><LF>
What is the Login Information for user 1?	?ETHERNET,3,1<CR><LF>
What is the Login Information for ALL users?	?ETHERNET,3,0<CR><LF> (Note: 0=ALL)
Response: ~DEVICE, Integration ID, Configuration Number, Parameters	
The IP Address is 192.168.250.1	~ETHERNET,0,192.168.250.1<CR><LF>



Quantum® System Commands *(continued)*

QSE-CI-NWK-E: INTEGRATION ID Commands

INTEGRATION ID Command Formats

Operation

?INTEGRATIONID, Action Number, Parameters

Command

Use "INTEGRATIONID" Command-specific fields tables to complete these command fields.

INTEGRATION ID Command-specific fields

- **Actions**

Description	Action #	Parameters
Get Integration ID for a Serial Number	1	Serial Number - 8 character HEX serial number of the device, Integration ID - The integration ID to be assigned.
Get Info from ID	3	Integration ID = The Integration ID that information is desired for. NOTE: If this field is left blank, all integration IDs will be printed.

Example INTEGRATION ID Commands

Operation	Command String
Execute: ?INTEGRATIONID, Integration ID, Action Number, Parameters	
Get the Integration ID for a serial number	?INTEGRATIONID,1,5678EFFF<CR><LF>
Response: ~INTEGRATIONID, Integration ID, Action Number, Parameters	
Get the Integration ID for a serial number	~INTEGRATIONID,1,5678EFFF,1<CR><LF>
Execute: ?INTEGRATIONID, Integration ID, Action Number, Parameters	
Get information about an Integration ID command	?INTEGRATIONID,3,1<CR><LF>
Response: ~INTEGRATIONID, Integration ID, Action Number, Parameters	
Get information about an Integration ID command	~INTEGRATIONID,3,1,DEVICE,5678EFFF<CR><LF>



Quantum® System Commands (continued)

QSE-CI-NWK-E: RESET Commands

RESET Command Formats

Operation

#RESET, Action Number

Command

Use "RESET Command-specific fields" tables to complete these command fields.

RESET Command-specific fields

- Action Numbers:

Action	Action Number
Restart the device	0
Restore to factory defaults	1

Example RESET Commands

Operation	Command String
Execute: #RESET, Action Number	
Restart the NWK	#RESET,0<CR><LF>
Restore NWK to factory defaults	#RESET,1<CR><LF>



Quantum® System Commands *(continued)*

QSE-CI-NWK-E: ERROR Response Strings

ERROR Command Formats

Operation

~ERROR, Error Number

Command

Use "ERROR Command-specific fields" tables to complete this field.

ERROR Command-specific fields

Error Number:

Description	Error Number
Parameter count mismatch	1
Object does not exist	2
Invalid action number	3
Parameter data out of range	4
Parameter data malformed	5

Example ERROR Messages

Operation	Command String
Parameter count mismatch: Too many or too few parameters for the specified action	
Too many parameters when activating scene	#AREA,2,6,1,1,1,1,1<CR><LF>
Parameter count mismatch.	~ERROR,1<CR><LF>
Object does not exist: The Integration ID or serial number entered does not map to a known part of the system	
Send command to an ID that is not valid	#OUTPUT,1234,1,100.00<CR><LF>
Object does not exist	~ERROR,2<CR><LF>
Invalid Action: The action does not exist for this command	
Send invalid action (4321) to Area 2.	#AREA,2,4321<CR><LF>
Invalid action number	~ERROR,3<CR><LF>
Parameter data out of range: The parameter data is out of range for this action	
Send Output 11 to 120%.	#OUTPUT,11,1,120.00<CR><LF>
Parameter data out of range	~ERROR,4<CR><LF>
Parameter data malformed: The parameter data given was not formatted properly	
Set Time to 12:23:24:25	#SYSTEM,1,12:23:24:25<CR><LF>
Invalid action number	~ERROR,5<CR><LF>



Quantum® System Commands (continued)

QSE-CI-NWK-E: AREA Commands

AREA Command Formats

Operation *Integration ID (example)*
#AREA^{1, 2}, 2, Action Number, Parameters
Command *Use "AREA Command-specific fields" tables to complete these command fields.*

AREA Command-specific fields

Action Numbers and Parameters:

Action	Action Number	Parameters
Set (#) Area Level	1	Level ³ = 0–100 or 0.00–100.00, Fade ⁴ in SS.ss ⁵ , SS, MM:SS, or HH:MM:SS ⁵ Delay ⁴ in SS.ss ⁵ , SS, MM:SS, or HH:MM:SS ⁵
Raise ⁶	2	None
Lower ⁶	3	None
Stop Raise/Lower	4	None
Set or Get Current Scene	6	Scene Number ⁷ = 0-32
Set or Get Daylighting Mode	7	1 = Active 2 = Inactive
Get Occupancy State	8	3 = Occupied 4 = Unoccupied
Set or Get Occupancy Mode	9	1 = Occupancy and Vacancy ⁸ 2 = Vacancy ⁸ 3 = Not Applicable ⁹ 4 = Inactive

Example AREA Messages

Operation	Command String
Execute: #AREA, Integration ID, Action Number, Parameters	
Set area level to 75% (Fade = 4 sec, Delay = 2 sec)	#AREA,2,1,70,4,2<CR><LF>
Lower Area.	#AREA,2,3<CR><LF>
Query: ?AREA, Integration ID, Action Number	
Is the area occupied?	?AREA,2,8<CR><LF>
What is the current active scene?	?AREA,2,6<CR><LF>
Response: ~AREA, Integration ID, Action Number, Parameters	
The area is currently occupied.	~AREA,2,8,3<CR><LF>
Area Scene 2 is currently active.	~AREA,2,6,2<CR><LF>



Quantum® System Commands (*continued*)

QSE-CI-NWK-E: AREA Commands (*continued*)

NOTES

1. AREA can only be used to control areas of a *Quantum* system that have been assigned to a particular integration access point. Please refer to the Q-Design™ software (Integration Tab) or *Quantum* Integration Report for details of what areas are available for control and monitoring.
2. AREA commands cannot be sent to areas that contain other areas, such as a floor or an entire building.
3. The Level is accepted as a percentage.
4. The Fade and Delay time are optional. When not used the system will use a one second fade time with zero second delay. The minimum fade and delay time is 0 seconds. The maximum fade and delay time is 4 hours.
5. Fractional seconds “SS.ss” will be rounded down to the nearest quarter second. For example, if a fade time is specified as 1.45 seconds a value of 1.25 seconds will be used.
6. When a Raise / Lower command is issued, the area’s level will continue to go towards high end / low end until a Stop command is received.
7. Scene 0 is the OFF Scene.
8. If After Hours is used in an area, setting the area’s Occupancy Mode to “Occupancy and Vacancy” or “Vacancy” will activate After Hours.
9. The area will report “Not Applicable” as its Occupancy Mode if the area does not have occupancy sensors and if After Hours is not used.

Lutron® integration protocol



Quantum® System Commands (continued)

QSE-CI-NWK-E: SHADEGRP Commands

SHADEGRP Command Formats

Operation *Integration ID (example)*
#SHADEGRP¹, 2, Action Number, Parameters
Command *Use "SHADEGRP Command-specific fields" tables to complete these command fields.*

SHADEGRP Command-specific fields

Action Numbers and Parameters:

Action	Action Number	Parameters
Set (#) Shade Group Level	1	Level ² = 0–100 or 0.00–100.00, Delay ³ in SS.ss ⁴ , SS, MM:SS, or HH:MM:SS ⁴
Raise ⁵	2	None
Lower ⁵	3	None
Stop Raise/Lower	4	None
Set or Get Current Preset	6	Preset Number ⁶ = 0-30

Example SHADEGRP Messages

Operation	Command String
Execute: #SHADEGRP, Integration ID, Action Number, Parameters	
Set shade group to 70% (Delay = 2 sec)	#SHADEGRP,2,1,70,2<CR><LF>
Lower shade group.	#SHADEGRP,2,3<CR><LF>
Query: ?SHADEGRP, Integration ID, Action Number	
What is the current active preset?	?SHADEGRP,2,6<CR><LF>
Response: ~SHADEGRP, Integration ID, Action Number, Parameters	
Shade group Preset 2 is currently active.	~SHADEGRP,2,6,2<CR><LF>

NOTES

- SHADEGRP can only be used to control shade groups of a *Quantum* system that have been assigned to a particular integration access point. Please refer to the Q-Design™ software (Integration Tab) or *Quantum* Integration Report for details of what shade groups are available for control and monitoring.
- The Level is accepted as a percentage, where 100% is fully open and 0% is fully closed.
- The Delay time is optional. When not used the system will use a zero second delay. The minimum delay time is 0 seconds. The maximum delay time is 4 hours.
- Fractional seconds “SS.ss” will be rounded down to the nearest quarter second. For example, if a delay time is specified as 1.45 seconds a value of 1.25 seconds will be used.
- When a Raise / Lower command is issued, the shade group’s level will continue to go towards open / close until a Stop command is received.
- Preset 0 is the Open Preset and Preset 30 is the Closed Preset.



Quantum® System Commands (continued)

QSE-CI-NWK-E: OUTPUT Commands

OUTPUT Command Format

$\begin{matrix} \text{Operation} & \text{Integration ID (example)} \\ \# \text{OUTPUT}^1, 2, & \text{Action Number, Parameters} \end{matrix}$
Command Use "OUTPUT Command-specific fields" tables
 to complete these command fields.

OUTPUT Command-specific fields

Action Numbers and Parameters:

Action	Action Number	Parameters
Set (#) or Get (?) Output Level	1	Level ² = 0–100 or 0.00–100.00, Fade ³ in SS.ss ⁴ , SS, MM:SS ⁴ , or HH:MM:SS ⁴ Delay ³ in SS.ss ⁴ , SS, MM:SS ⁴ , or HH:MM:SS ⁴
Raise ⁵	2	None
Lower ⁵	3	None
Stop Raise/Lower ⁵	4	None
Pulse	6	Pulse ⁶ time in SS.ss ⁴ , MM:SS.ss ⁴ , or HH:MM:SS.ss ⁴ , or Delay ³ in SS.ss ⁴ , SS, MM:SS ⁴ , or HH:MM:SS ⁴

Example OUTPUT Messages

Operation	Command String
Execute: #OUTPUT, Integration ID, Action Number, Parameters	
Set output level to 70% (Fade = 4 sec, Delay = 2 sec)	#OUTPUT,2,1,70,4,2<CR><LF>
Raise Output	#OUTPUT,2,2<CR><LF>
Query: ?OUTPUT, Integration ID	
What is the current output level?	?OUTPUT,2<CR><LF>
Response³: ~OUTPUT, Integration ID, Action Number, Parameters	
Output level is set to 48%.	~OUTPUT,2,1,48<CR><LF>

NOTES

- OUTPUT commands can be used to control system lighting zones, individual shades, and contact closed outputs.
- The Level is taken as a percentage.
- The Fade and Delay time are optional. When not used the system will use a one second fade time with zero second delay. The minimum fade and delay time is 0 seconds. The maximum fade and delay time is 4 hours. For shade outputs, the Fade parameter has no effect (since shades have fixed speeds) but it is required when specifying an optional delay.
- Fractional seconds "SS.ss" will be rounded down to the nearest quarter second. For example, if a fade time is specified as 1.45 seconds a value of 1.25 seconds will be used.
- When a Raise / Lower command is issued, the output's level will continue to go towards high end / low end until a Stop command is received.
- The default time is one second.



Quantum® System Commands (continued)

QSE-CI-NWK-E: SYSTEM Commands

SYSTEM Command Formats

Operation

#SYSTEM, Action Number, Parameters

Command

Use "SYSTEM Command-specific fields" tables to complete these command fields.

SYSTEM Command-specific fields

Action Numbers and Parameters:

Action	Action Number	Parameters
Set (#) or Get (?)Time ¹	1	Time in HH, HH:MM, or HH:MM:SS
Set or Get Date	2	Date in MM/DD/YYYY
Set or Get Latitude and Longitude	4	Latitude = -90.00 to +90.00 degrees Longitude = -180.00 to +180.00 degrees
Set or Get Time Zone ²	5	Hours = -12 to 12 Minutes = 0 to 59
Get Sunset	6	None
Get Sunrise	7	None
Get OS Rev	8	None

Example SYSTEM Messages

Operation	Command String
Execute: #SYSTEM, Integration ID, Action Number, Parameters	
Set time to 5:45 PM.	#SYSTEM1,17:45<CR><LF>
Set date to June 1, 2009.	#SYSTEM,2,06/01/2009<CR><LF>
Query: ?SYSTEM, Integration ID, Action Number	
What is the system time?	?SYSTEM,1<CR><LF>
What is the system date?	?SYSTEM,2<CR><LF>
Response: ~SYSTEM, Integration ID, Action Number, Parameters	
The system time is 11:05 AM..	~SYSTEM,1,11:05:00<CR><LF>
The system date is July 3, 2009	~SYSTEM,2,07/03/2009<CR><LF>

NOTES

1. The system time must be entered in 24 hour format.
2. The Time Zone is referenced to GMT.



Quantum® System Commands (continued)

QSE-CI-NWK-E: HELP Commands

HELP Command Formats

Operation

?HELP, Command Name¹, Action Number²

Command

Example HELP Messages

Operation	Command String
Query: #HELP, Command Name, Action Number	
What are all the supported Integration Commands?	?HELP<CR><LF>
What actions are available for #OUTPUT?	?HELP,#OUTPUT<CR><LF>
How is “Raise” used for #OUTPUT?	?HELP,#OUTPUT,2<CR><LF>
Response: ~HELP, Help Information	
The list of all Integration Commands.	#OUTPUT,?OUTPUT,#DEVICE,?DEVICE,#AREA,?AREA,#TIMECLOCK,?TIMECLOCK,#SYSTEM,?SYSTEM,#MONITORING,?MONITORING,<CR><LF>
The help information for the #OUTPUT command.	~HELP, #OUTPUT requires action<1-6><CR><LF> 1 = Set Level/Position 2 = Raise 3 = Lower 4 = Stop Raise/Lower 6 = Pulse USAGE: #OUTPUT, <ID>, <action>,<CR><LF>
The help information for the “Raise” action (#OUTPUT).	~HELP, #OUTPUT, <action=2> start raising output level<CR><LF> USAGE: #OUTPUT, <ID>,<action=2><CR><LF>

NOTES

1. The “Command Name” parameter is optional. If not entered, a list of all the supported Integration Commands will be printed. If a supported command name is entered, the corresponding actions will be listed.
2. The “Action” parameter is optional. When a valid action number is entered (i.e. it is supported by the corresponding “Command Name”), the help information for that particular action will be displayed.

Stanza® Keypads

Models: SZ-2B, SZ-3B, SZ-4B, SZ-3/1B, SZ-5B

SZ-2B

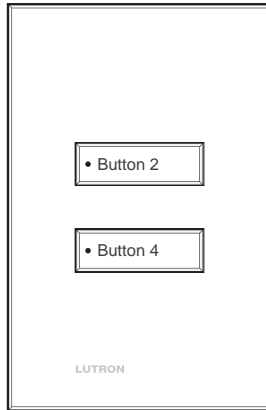

SZ-3B

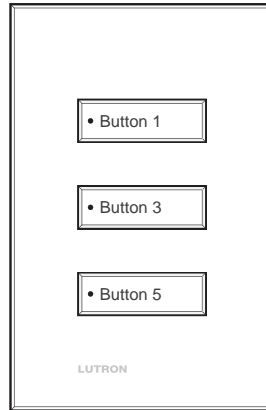

SZ-4B

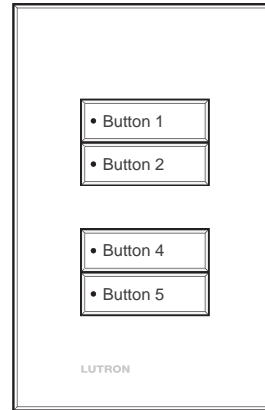

SZ-3/1B

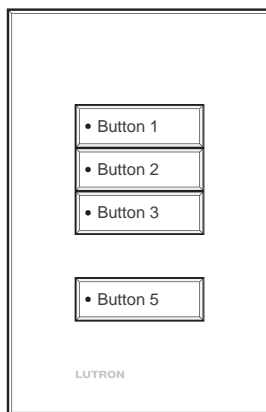

SZ-5B

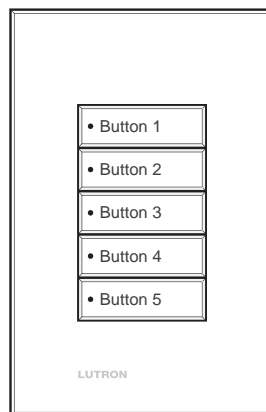

Why integrate with a keypad?

- Monitor button events and LED status
- Simulate a button press

Integration Capabilities

- Up to five programmable buttons with LEDs (use DEVICE command).

Supported Command Types

- **DEVICE** allows control and monitoring of button presses, releases, and LEDs.

Compatibility

	Stanza	QS Standalone	Quantum®	RadioRA® 2
Stanza Keypad	✓			

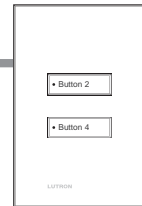

Stanza® Keypads: DEVICE Commands

DEVICE Command Formats

^{Operation}
^{Integration ID (example)}
#DEVICE, 2, Component Number, Action Number, Parameters
_{Command} *Use "DEVICE Command-specific fields" tables to complete these command fields.*

DEVICE Command-specific fields

Component Number:

Component	Component Number	Available Actions
Button 1	4	Press, Release
Button 2	5	Press, Release
Button 3	6	Press, Release
Button 4	7	Press, Release
Button 5	8	Press, Release
LED 1	15	Get (?) LED state
LED 2	16	Get (?) LED state
LED 3	17	Get (?) LED state
LED 4	18	Get (?) LED state
LED 5	19	Get (?) LED state

Action Numbers and Parameters:

Action	Action Number	Parameters
Press	3	None
Release	4	None
Get (?) LED state	9	None

Example DEVICE Messages

Examples presume keypad has been assigned Integration ID 2.

Operation	Command String
Execute: #DEVICE, Integration ID, Component Number, Action Number, Parameters	
Press Button 1.	#DEVICE,2,4,3<CR><LF>
Query: ?DEVICE, Integration ID, Component Number, Action Number	
What is the state of LED 1?	?DEVICE,2,15,9<CR><LF>
Response: ~DEVICE, Integration ID, Component Number, Action Number, Parameters	
LED 1 is on.	~DEVICE,2,15,9,1<CR><LF>

Tabletop Stanza® Keypads

Models: SZ-LB-CPN5311 (actual model number will depend on number/position of buttons and product color)

SZLB-CPN5311

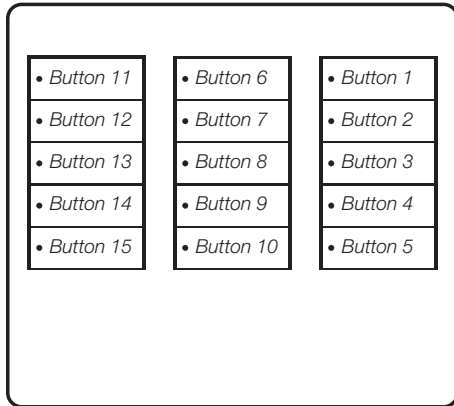

Why Integrate with a Tabletop Keypad?

- Simulate a button press
- Monitor button events and LED status

Additional Commands

None

Compatibility

	Stanza®	QS Standalone	Quantum®	RadioRA 2
Tabletop Stanza	✓			

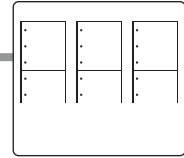

Tabletop Stanza® Keypads:

DEVICE Commands

DEVICE Command Formats

Operation *Integration ID (example)*
#DEVICE, 3, Component Number, Action Number, Parameters
Command *Use "DEVICE Command-specific fields" tables to complete these command fields.*

DEVICE Command-specific fields

- Component Number:**

Component	Component Number	Available Actions
Button 1	2	Press, Release
Button 2	3	Press, Release
Button 3	4	Press, Release
Button 4	5	Press, Release
Button 5	6	Press, Release
Button 6	7	Press, Release
Button 7	8	Press, Release
Button 8	9	Press, Release
Button 9	10	Press, Release
Button 10	11	Press, Release
Button 11	12	Press, Release
Button 12	13	Press, Release
Button 13	14	Press, Release
Button 14	15	Press, Release
Button 15	16	Press, Release

Component numbers continued on next page...

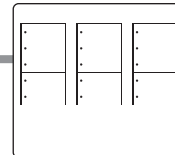

Tabletop Stanza® Keypads: DEVICE Commands

DEVICE Command Formats

^{Operation}
^{Integration ID (example)}
 #DEVICE, 3, Component Number, Action Number, Parameters
_{Command} _{Use "DEVICE Command-specific fields" tables to complete these command fields.}

- Component Number: (continued)**

Component	Component Number	Available Actions
LED 1	82	Get LED state
LED 2	83	Get LED state
LED 3	84	Get LED state
LED 4	85	Get LED state
LED 5	86	Get LED state
LED 6	87	Get LED state
LED 7	88	Get LED state
LED 8	89	Get LED state
LED 9	90	Get LED state
LED 10	91	Get LED state
LED 11	92	Get LED state
LED 12	93	Get LED state
LED 13	94	Get LED state
LED 14	95	Get LED state
LED 15	96	Get LED state

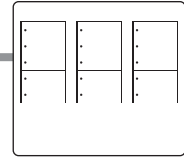

Tabletop Stanza® Keypads:

DEVICE Commands

- Actions and Parameters:**

Action	Action Number	Parameters
Press	3	None
Release	4	None
Get (?) LED State	9	0=Off 1=On

Example DEVICE Commands

Examples presume keypad has been assigned Integration ID 3.

Operation	Command String
Execute: #DEVICE, Integration ID, Component Number, Action Number, Parameters	
Press Button 1.	# <i>DEVICE</i> ,3,1,3<CR><LF>
Query: ?DEVICE, Integration ID, Component Number, Action Number	
What is the state of LED 1?	? <i>DEVICE</i> ,3,82,9<CR><LF>
Response: ~DEVICE, Integration ID, Component Number, Action Number, Parameters	
LED 1 is on.	~ <i>DEVICE</i> ,3,82,9,1<CR><LF>

Stanza® Dimmers

Models: SZ-6D, SZ-6ND, SZ-3PD

SZ-6D, SZ-6ND

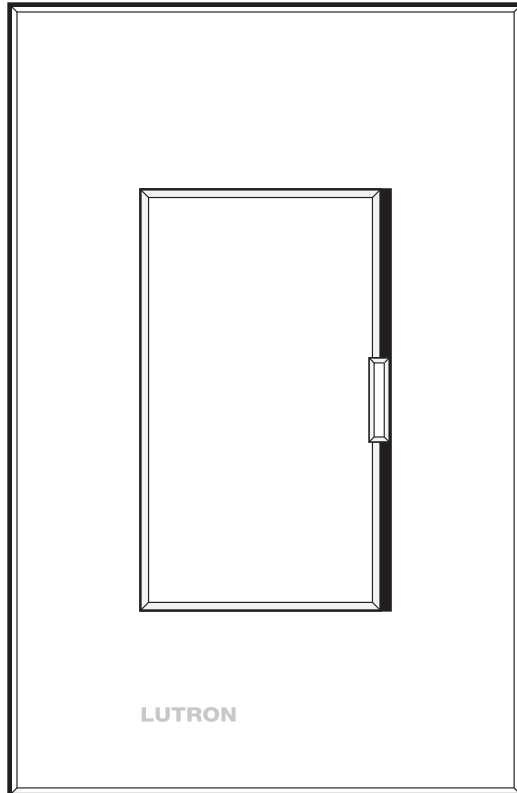

SZ-3PD

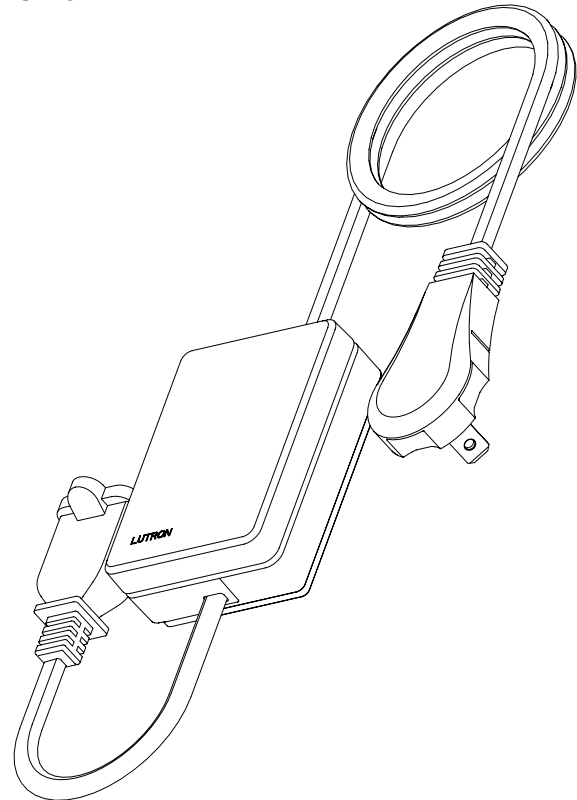

Why Integrate with a Dimmer?

- Turn on to specific light level or off
- Query current light level

Integration Capabilities

- One controllable output (use OUTPUT command)

Supported Command Types

- **OUTPUT** allows control and monitoring of the dimmer device output.

Compatibility

	<i>Stanza</i>	QS Standalone	Quantum®	RadioRA® 2
<i>Stanza</i> Dimmer	✓			

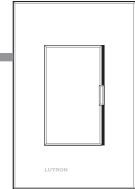

Stanza® Dimmers: OUTPUT Commands

OUTPUT Command Format

^{Operation}
^{Integration ID (example)}
#OUTPUT, 1, Action Number, Parameters
_{Command}

Use "OUTPUT Command-specific fields" tables to complete these command fields.

OUTPUT Command-specific fields

Action Numbers and Parameters:

Action	Action Number	Parameters
Set (#) or Get (?) Zone Level	1	Level = 0–100 or 0.00–100.00, Fade ¹ in SS.ss ² , SS, MM:SS, or HH:MM:SS Delay ¹ in SS.ss ² , SS, MM:SS, or HH:MM:SS

Example OUTPUT Messages

Examples presume dimmer has been assigned Integration ID 1.

Operation	Command String
Execute: #OUTPUT, Integration ID, Action Number, Parameters	
Set dimmer to 75% with a 1 min 30 sec fade.	#OUTPUT,1,1,75,01:30<CR><LF>
Query: ?OUTPUT, Integration ID, Action Number	
What is the state of the output?	?OUTPUT,1,1<CR><LF>
Response³: ~OUTPUT, Integration ID, Action Number, Parameters	
Output level is set to 90%.	~OUTPUT,1,1,90.00<CR><LF>

NOTES

1. The Fade and Delay time are optional. When not used the system will use a one second fade time with zero second delay. The minimum fade and delay time is 0.25 seconds. The maximum fade and delay time is 4 hours.
2. Fractional seconds "SS.ss" will be rounded down to the nearest quarter second. For example, if a fade time is specified as 1.45 seconds a value of 1.25 seconds will be used.
3. The system will report the target level of dimmers and switches while a fade or delay is in progress. The actual level is not transmitted while a fade or delay is in progress.
Example: If the "Over Sink" (1) dimmer is at 20% and is then commanded to go to 100% by sending #OUTPUT,1,1,100 the response from the system will be ~OUTPUT,1,1,100.00

Stanza® Switch

Model: SZ-6ANS

SZ-6ANS

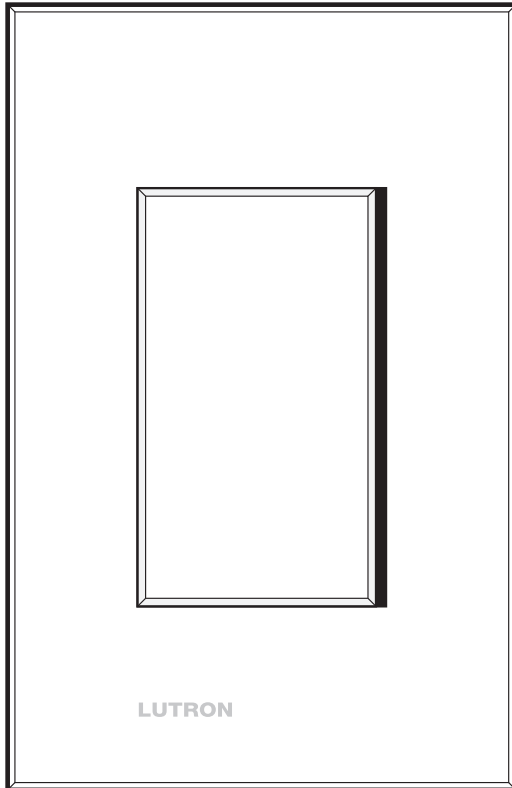

Why Integrate with a Switch?

- Turn on or off
- Query current light level

Integration Capabilities

- One controllable output (use OUTPUT command)

Supported Command Types

- **OUTPUT** allows control and monitoring of the switch output.

Compatibility

	<i>Stanza</i>	QS Standalone	Quantum®	RadioRA® 2
Stanza Switch	✓			

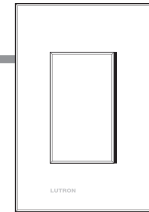

Stanza® Switch: OUTPUT Commands

OUTPUT Command Format

^{Operation}
^{Integration ID (example)}
#OUTPUT, 1, Action Number, Parameters
_{Command}

Use "OUTPUT Command-specific fields" tables to complete these command fields.

OUTPUT Command-specific fields

Action Numbers and Parameters:

Action	Action Number	Parameters
Set (#) or Get (?) Zone Level	1	Level ¹ = 0–100 or 0.00–100.00, Fade ² in SS.ss ³ , SS, MM:SS, or HH:MM:SS Delay ² in SS.ss ³ , SS, MM:SS, or HH:MM:SS

Example OUTPUT Messages

Examples presume switch has been assigned Integration ID 1.

Operation	Command String
Execute: #OUTPUT, Integration ID, Action Number, Parameters	
Set switch to 100% with a 1 min 30 sec fade.	#OUTPUT,1,1,100,01:30<CR><LF>
Query: ?OUTPUT, Integration ID, Action Number	
What is the state of the output?	?OUTPUT,1,1<CR><LF>
Response⁴: ~OUTPUT, Integration ID, Action Number, Parameters	
Output level is set to 100%.	~OUTPUT,1,1,100.00<CR><LF>

NOTES

- Any level greater than 0 will turn ON the output. When level is equal to 0 the output will turn OFF.
- Fractional seconds "SS.ss" will be rounded down to the nearest quarter second. For example, if a fade time is specified as 1.45 seconds a value of 1.25 seconds will be used.
- For switches, the fade parameter has no effect but it is required when specifying an optional delay. The minimum fade and delay time is 0.25 seconds. The maximum fade and delay time is 4 hours.
- The system will report the target level of dimmers and switches while a fade or delay are in progress. The actual level is not transmitted while a fade or delay are in progress.

Stanza® Lamp Module

Model: SZ-1SD

SZ-1SD

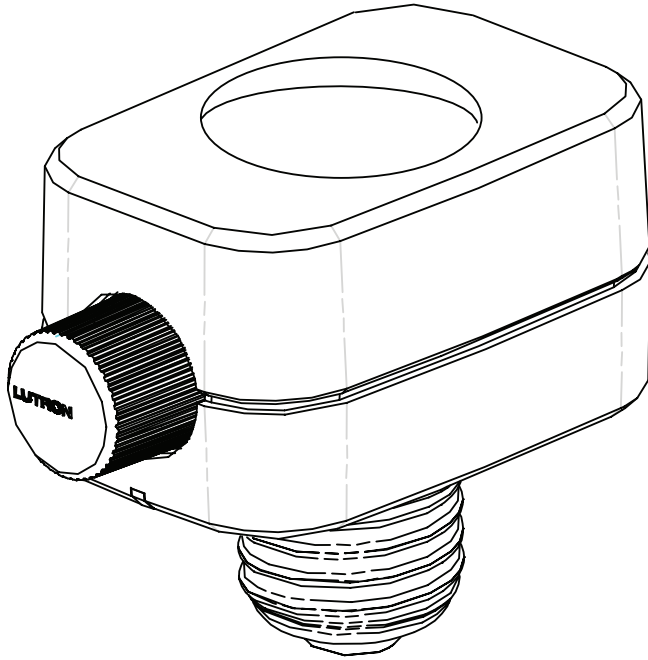

Why Integrate with a Lamp Module?

- Turn on to specific light level or off
- Query current light level

Integration Capabilities

- One controllable output (use OUTPUT command)

Supported Command Types

- **OUTPUT** allows control and monitoring of the lamp module output.

Compatibility

	<i>Stanza</i>	QS Standalone	Quantum®	RadioRA® 2
Stanza Lamp Module	✓			

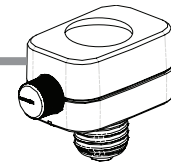

Stanza® Lamp Module: OUTPUT Commands

OUTPUT Command Format

$\begin{matrix} \text{Operation} & \text{Integration ID (example)} \\ | & | \\ \# \text{OUTPUT, } 1, & \text{Action Number, Parameters} \\ | & | \\ \text{Command} & \text{Use "OUTPUT Command-specific fields" tables} \\ & \text{to complete these command fields.} \end{matrix}$

OUTPUT Command-specific fields

Action Numbers and Parameters:

Action	Action Number	Parameters
Set (#) or Get (?) Zone Level	1	Level = 0–100 or 0.00–100.00, Fade ¹ in SS.ss ² , SS, MM:SS, or HH:MM:SS Delay ¹ in SS.ss ² , SS, MM:SS, or HH:MM:SS

Example OUTPUT Messages

Examples presume dimmer has been assigned Integration ID 1.

Operation	Command String
Execute: #OUTPUT, Integration ID, Action Number, Parameters	
Set dimmer to 75% with a 1 min 30 sec fade.	#OUTPUT,1,1,75,01:30<CR><LF>
Query: ?OUTPUT, Integration ID, Action Number	
What is the state of the output?	?OUTPUT,1,1<CR><LF>
Response³: ~OUTPUT, Integration ID, Action Number, Parameters	
Output level is set to 90%.	~OUTPUT,1,1,90.00<CR><LF>

NOTES

- The Fade and Delay time are optional. When not used the system will use a one second fade time with zero second delay. The minimum fade and delay time is 0.25 seconds. The maximum fade and delay time is 4 hours.
- Fractional seconds “SS.ss” will be rounded down to the nearest quarter second. For example, if a fade time is specified as 1.45 seconds a value of 1.25 seconds will be used.
- The system will report the target level of dimmers and switches while a fade or delay are in progress. The actual level is not transmitted while a fade or delay are in progress..
Example: If the “Bedside Lamp” (1) dimmer is at 20% and is then commanded to go to 100% by sending #OUTPUT, 1, 1, 100 the response from the system will be ~OUTPUT, 1, 1, 100.00

Stanza® Input/Output Interface

Model: SZ-IO

SZ-IO

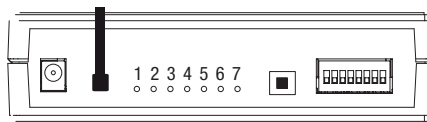
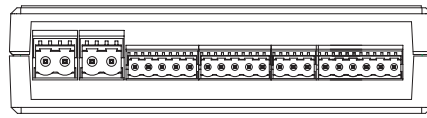

Why Integrate with an SZ-IO Contact Closure Interface?

- Integrates a *Stanza* control system with equipment that has contact-closure I/O, including:
 - Motion and occupant sensors
 - Timeclocks and push buttons
 - A/V equipment
 - Security systems

Integration Capabilities

- Five programmable contact closure input buttons (use **DEVICE** command)

Supported Command Types

- **DEVICE** allows control and monitoring of contact closure inputs.

Compatibility

	Stanza	QS Standalone	Quantum®	RadioRA® 2
<i>Stanza</i> Input/Output Interface	✓			



Stanza® SZ-IO: DEVICE Commands

DEVICE Command Formats

^{Operation} ^{Integration ID (example)}
#DEVICE, 2, Component Number, Action Number, Parameters
_{Command} *Use "DEVICE Command-specific fields" tables to complete these command fields.*

DEVICE Command-specific fields

Component Number:

Component	Component Number	Available Actions
CCI 1	3	Close, Open
CCI 2	4	Close, Open
CCI 3	5	Close, Open
CCI 4	6	Close, Open
CCI 5	7	Close, Open
CCI LED 1	8	Get (?) LED state
CCI LED 2	9	Get (?) LED state
CCI LED 3	10	Get (?) LED state
CCI LED 4	11	Get (?) LED state
CCI LED 5	12	Get (?) LED state

Action Numbers and Parameters:

Action	Action Number	Parameters
Close	3	None
Open	4	None
Get (?) LED state	9	None

Example DEVICE Messages

Examples presume CCI has been assigned Integration ID 2.

Operation	Command String
Execute: #DEVICE, Integration ID, Component Number, Action Number, Parameters	
Close CCI1.	#DEVICE,2,4,3<CR><LF>
Query: ?DEVICE, Integration ID, Component Number, Action Number	
What is the state of LED 1?	?DEVICE,2,8,9<CR><LF>
What is the state of CCI 3?	?DEVICE,2,4<CR><LF>
Response: ~DEVICE, Integration ID, Component Number, Action Number, Parameters	
LED 1 is on.	~DEVICE,2,8,9,1<CR><LF>

GRAFIK Eye® QS Main Unit

Model: QSG

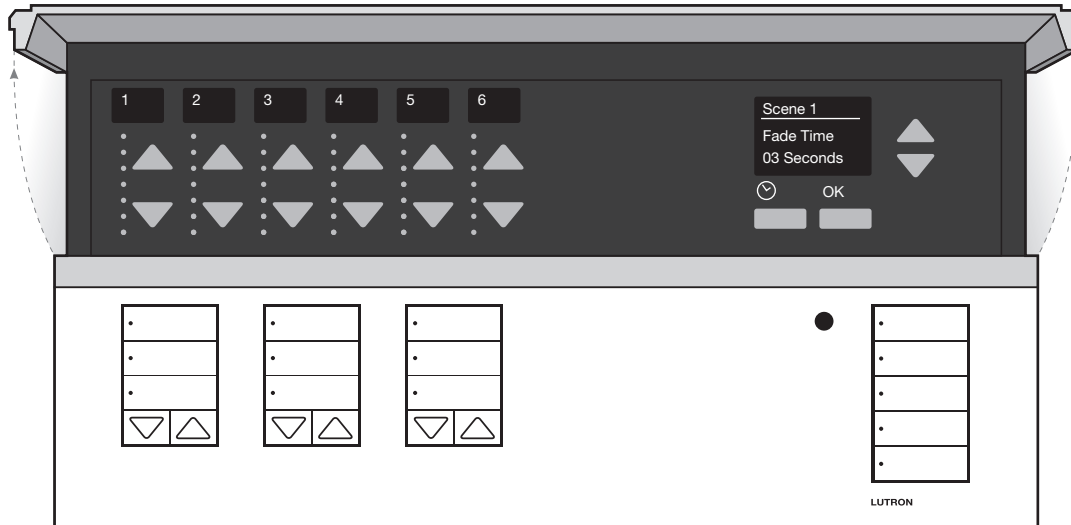

Why Integrate with a GRAFIK Eye?

- Control individual lights and scenes
- Query current scene and light levels
- Control LEDs of unprogrammed buttons

Integration Capabilities

- 16 scenes and up to 24 controllable outputs (output count depends on model)

Supported Command Types

- **DEVICE** allows control and monitoring of buttons, LEDs and scenes.
- **OUTPUT** allows control and monitoring of the dimmer device output.

Compatibility

	Stanza®	QS Standalone	Quantum®	RadioRA® 2
GRAFIK Eye QS Main Unit		✓	✓	✓

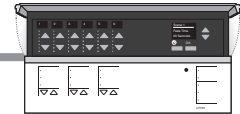

GRAFIK Eye® QS: DEVICE Commands

DEVICE Command Formats

Operation *Integration ID (example)*
#DEVICE, 5, Component Number, Action Number, Parameters
Command *Use "DEVICE Command-specific fields" tables to complete these command fields.*

DEVICE Command-specific fields

- Component Number:**

Component	Component Number	Available Actions
Zone 1 Controller - Zone 24 Controller	1-24	Raise, Lower, Stop, Set Light Level
Scene 1 Button	70	Press, Release
Scene 2 Button	71	Press, Release
Scene 3 Button	76	Press, Release
Scene 4 Button	77	Press, Release
Scene Off Button	83	Press, Release
Shade Column 1 Open	38	Press, Release
Shade Column 1 Preset 1	39	Press, Release
Shade Column 1 Close	40	Press, Release
Shade Column 1 Lower	41	Press, Release
Shade Column 1 Raise	47	Press, Release
Shade Column 2 Open	44	Press, Release
Shade Column 2 Preset 1	45	Press, Release
Shade Column 2 Close	46	Press, Release
Shade Column 2 Lower	52	Press, Release
Shade Column 2 Raise	53	Press, Release
Shade Column 3 Open	50	Press, Release
Shade Column 3 Preset 1	51	Press, Release
Shade Column 3 Close	56	Press, Release
Shade Column 3 Lower	57	Press, Release
Shade Column 3 Raise	58	Press, Release
Scene Controller	141	Set Current Scene, Set Zone Lock, Set Scene Lock, Set Sequence State, Raise, Lower, Stop
Scene 1 LED	201	Get (?) LED state
Scene 2 LED	210	Get (?) LED state
Scene 3 LED	219	Get (?) LED state
Scene 4 LED	228	Get (?) LED state
Scene Off LED	237	Get (?) LED state

Continued on next page...

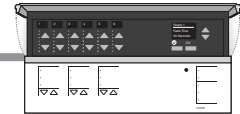

GRAFIK Eye® QS: DEVICE Commands *(continued)*

DEVICE Command-specific fields

- Component Number (continued):**

Component	Component Number	Available Actions
Shade Column 1 Open LED	174	Get (?) LED state
Shade Column 1 Preset 1 LED	175	Get (?) LED state
Shade Column 1 Close LED	211	Get (?) LED state
Shade Column 2 Open LED	183	Get (?) LED state
Shade Column 2 Preset 1 LED	184	Get (?) LED state
Shade Column 2 Close LED	220	Get (?) LED state
Shade Column 3 Open LED	192	Get (?) LED state
Shade Column 3 Preset 1 LED	193	Get (?) LED state
Shade Column 3 Close LED	229	Get (?) LED state

- Action Numbers and Parameters:**

Action	Action Number	Parameters
Press	3	None
Release	4	None
Set Current Scene	7	Scene
Set (#) or Get (?) LED State ³	9	0=Off 1=On 2=Normal-Flash: 1 flash every second 3=Rapid-Flash: 10 flashes every second
Set Light Level	14	Level = 0–100 or 0.00–100.00, Fade in SS.ss ¹ , SS, MM:SS, or HH:MM:SS ² Delay ⁵ in SS.ss ¹ , SS, MM:SS, or HH:MM:SS ²
Set Zone Lock ⁴	15	0=Off; 1=On
Set Scene Lock ⁴	16	0=Off; 1=On
Set Sequence State ⁴	17	0=Off 1=Sequence through Scenes 1-4 2=Sequence through Scenes 5-16
Raise	18	None
Lower	19	None
Stop	20	None

NOTES

The number of zone controllers available matches the number of zones a particular model supports.

- Fractional seconds “SS.ss” will be rounded down to the nearest quarter second. For example, if a fade time is specified as 1.31 seconds a value of 1.25 seconds will be used.
- The Fade and Delay time are optional. When not used, the system will use a one second fade time with zero second delay.
- Quantum only. Set is for unprogrammed buttons only.
- QS Standalone only.
- Not supported in QS Standalone.

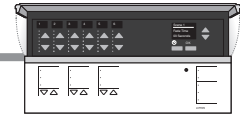

GRAFIK Eye® QS: OUTPUT Commands

OUTPUT Command Format

Operation *Integration ID (example)*
#OUTPUT, 1, Action Number, Parameters
Command Use "OUTPUT Command-specific fields" tables
 to complete these command fields.

OUTPUT Command-specific fields

- Action Numbers and Parameters:**

Action	Action Number	Parameters
Set or Get Zone Level	1	Level = 0–100 or 0.00–100.00, Fade in SS.ss ¹ , SS, MM:SS, or HH:MM:SS ² Delay ³ in SS.ss ¹ , SS, MM:SS, or HH:MM:SS ²
Start Raising	2	None
Start Lowering	3	None
Stop Raising/Lowering	4	None

Example OUTPUT Commands

Operation	Command String
Execute: #OUTPUT, Integration ID, Action Number, Parameters	
Set dimmer to 75% with a 1 min 30 sec fade.	#OUTPUT,1,1,75,01:30<CR><LF>
Start Raising zone level.	#OUTPUT,1,2<CR><LF>
Stop Raising/Lowering zone level.	#OUTPUT,1,4<CR><LF>
Query: ?OUTPUT, Integration ID, Action Number	
What is the state of the output?	?OUTPUT,1,1<CR><LF>
Response⁴: ~OUTPUT, Integration ID, Action Number, Parameters	
Output level is set to 90%.	~OUTPUT,1,1,90.00<CR><LF>

NOTES

- Fractional seconds "SS.ss" will be rounded down to the nearest quarter sec. For example, if a fade time is specified as 1.31 seconds a value of 1.25 seconds will be used.
- The Fade and Delay time are optional. When not used the system will use a one second fade time with zero second delay.
- Not supported in QS Standalone.
- The system will report the target level of a dimmer while it is fading from one level to another. The actual level is not transmitted while dimming between levels.
Example: If the "Over Sink" (Integration ID - 1) dimmer is at 20% and is then commanded to go to 100% by sending #OUTPUT, 1, 1, 100 the response from the system will be ~OUTPUT, 1, 1, 100.00

Energi Savr Node™ QS for DALI

Model: QSNE-2DAL-D

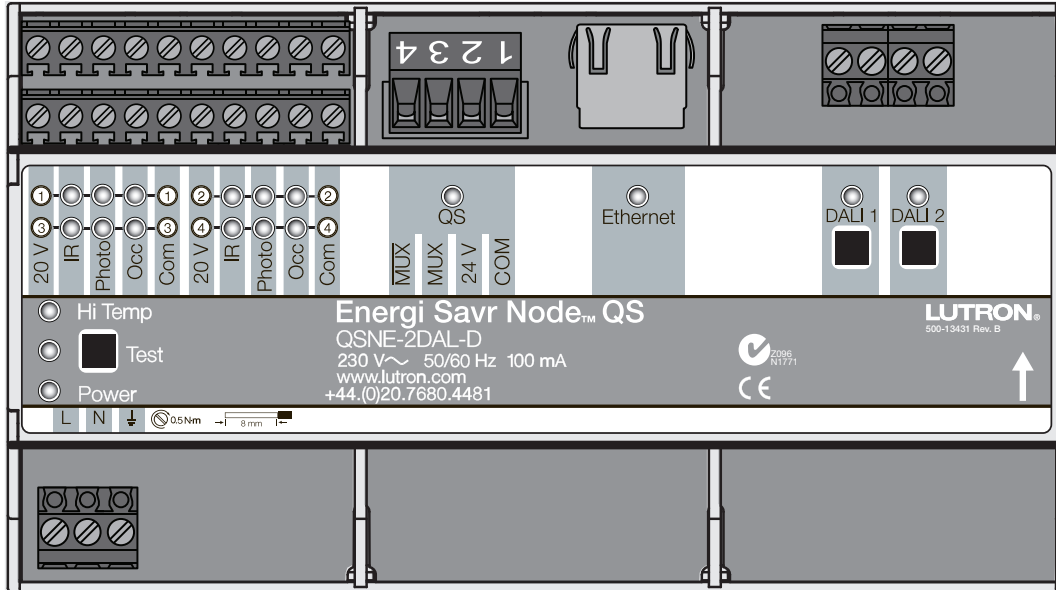

Why Integrate with an Energi Savr Node™ QS for DALI (ESN)?

- Control individual zones and scenes in an area
- Query current scene and light levels

Integration Capabilities

- Up to 32 areas with 16 scenes per area. Up to 32 zones across the two DALI buses

Supported Command Types

- **DEVICE** allows control and monitoring of zone levels and area scenes.
- **OUTPUT** allows control and monitoring of the dimmer device output.

Compatibility

	Stanza®	QS Standalone	Quantum®	RadioRA® 2
ESN		✓	✓	

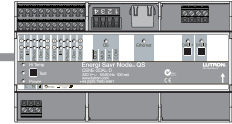

Energi Savr Node™ QS for DALI DEVICE Commands

DEVICE Command Formats

Operation *Integration ID (example)*
#DEVICE, 5, Component Number, Action Number, Parameters
Command *Use "DEVICE Command-specific fields" tables to complete these command fields.*

DEVICE Command-specific fields

- Action Numbers** and **Parameters:**

Component	Component Number	Available Actions
Zone 1 – Zone 32 ^{1,2,3}	201 – 232	Set or Get Light Level, Raise, Lower, Stop
Area 1 – Area 32 ^{1,3}	401 – 432	Set or Get Scene, Set Light Level, Raise, Lower, Stop

NOTES

- Zones and areas are created and configured using Lutron's ESN Configuration Tool on an iPhone® or iPod touch® mobile device, or the Quantum® Q-Design™ Tool. Only those areas and zones which have been configured using one of these tools are accessible through integration.
- Assigned zones can be given an individual Integration ID and controlled using the **#OUTPUT** command. For more details on setting the output Integration ID of a zone component, see the Integration Access Point section of the system that contains the ESN.
- When the ESN is part of a *Quantum* system, then the **#AREA** and **#OUTPUT** commands found in the *Quantum* "System Commands" section of this integration document should be used.

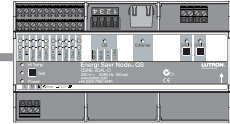

Energi Savr Node™ QS for DALI DEVICE Commands *(continued)*

DEVICE Command-specific fields

- **Action Numbers** and **Parameters:**

Action	Action Number	Parameters
Set Current Scene	7	Scene
Set Light Level	14	Level = 0–100 or 0.00–100.00, Fade in SS.ss ¹ , SS, MM:SS, or HH:MM:SS ² Delay ³ in SS.ss ¹ , SS, MM:SS, or HH:MM:SS ²
Raise	18	None
Lower	19	None
Stop	20	None

NOTES

1. Fractional seconds “SS.ss” will be rounded down to the nearest quarter second. For example, if a fade time is specified as 1.31 seconds a value of 1.25 seconds will be used.
2. The Fade and Delay time are optional. When not used, the system will use a one second fade time with zero second delay.
3. Not supported in QS Standalone.

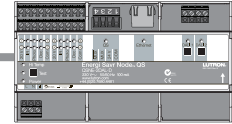

Energi Savr Node™ QS for DALI OUTPUT Commands

OUTPUT Command Format

Operation *Integration ID (example)*
#OUTPUT, 1, Action Number, Parameters
Command *Use "OUTPUT Command-specific fields" tables to complete these command fields.*

OUTPUT Command-specific fields

- Action Numbers and Parameters:**

Action	Action Number	Parameters
Set or Get Zone Level	1	Level = 0–100 or 0.00–100.00, Fade in SS.ss ¹ , SS, MM:SS, or HH:MM:SS ² Delay ³ in SS.ss ¹ , SS, MM:SS, or HH:MM:SS ²
Start Raising	2	None
Start Lowering	3	None
Stop Raising/Lowering	4	None

Example OUTPUT Commands

Operation	Command String
Execute: #OUTPUT, Integration ID, Action Number, Parameters	
Set dimmer to 75% with a 1 min 30 sec fade.	#OUTPUT,1,1,75,01:30<CR><LF>
Start Raising zone level.	#OUTPUT,1,2<CR><LF>
Stop Raising/Lowering zone level.	#OUTPUT,1,4<CR><LF>
Query: ?OUTPUT, Integration ID, Action Number	
What is the state of the output?	?OUTPUT,1,1<CR><LF>
Response⁴: ~OUTPUT, Integration ID, Action Number, Parameters	
Output level is set to 90%.	~OUTPUT,1,1,90.00<CR><LF>

NOTES

- Fractional seconds "SS.ss" will be rounded down to the nearest quarter second. For example, if a fade time is specified as 1.31 seconds a value of 1.25 seconds will be used.
- The Fade and Delay time are optional. When not used the system will use a one second fade time with zero second delay.
- Not supported in QS Standalone.
- The system will report the target level of a dimmer while it is fading from one level to another. The actual level is not transmitted while dimming between levels.
Example: If the "Over Sink" (Integration ID - 1) dimmer is at 20% and is then commanded to go to 100% by sending #OUTPUT, 1, 1, 100 the response from the system will be ~OUTPUT, 1, 1, 100.00

Energi Savr Node™ QS for International 0-10V / Switching

Models: QSNE-4T10-D, QSNE-4S10-D

QSNE-4T10-D

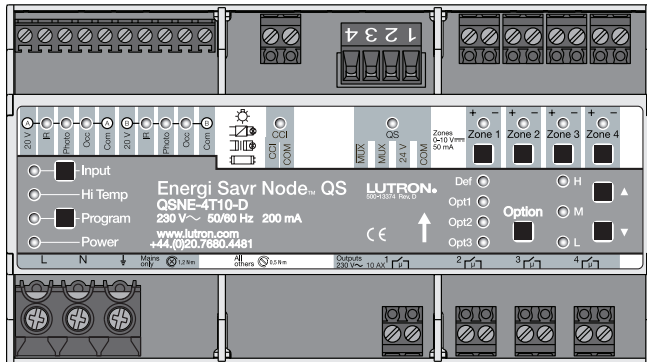

QSNE-4S10-D

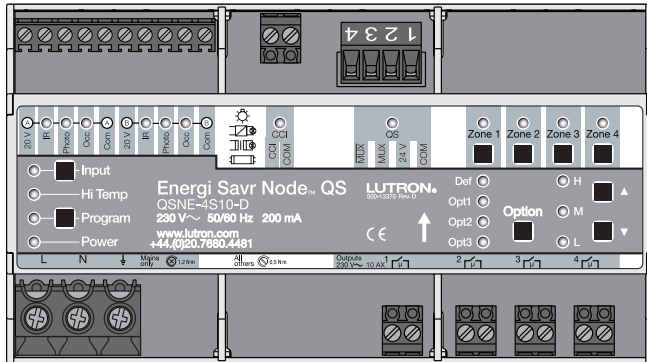

Why Integrate with an Energi Savr Node™ (ESN)?

- Control individual zones and scenes in an area
- Query current scene and light levels

Integration Capabilities

- Four areas with 16 scenes per area. Four zones on four independent outputs

Supported Command Types

- **DEVICE** allows control and monitoring of zone levels and area scenes.
- **OUTPUT** allows control and monitoring of the dimmer device output.

Compatibility

	Stanza®	QS Standalone	Quantum®	RadioRA® 2
ESN Int'l 0-10V/Switching		✓	✓	

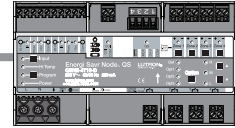

Energize Node™ QS for International 0-10V / Switching

DEVICE Commands

DEVICE Command Formats

Operation *Integration ID (example)*
#DEVICE, 5, Component Number, Action Number, Parameters
Command Use "DEVICE Command-specific fields" tables
to complete these command fields.

DEVICE Command-specific fields

- **Action Numbers** and **Parameters:**

Component	Component Number	Available Actions
Zone 1 – Zone 4 ^{1,2,3}	5 – 8	Set or Get Light Level, Raise, Lower, Stop
Area 1 – Area 4 ^{1,3}	10 – 13	Set or Get Scene, Set Light Level, Raise, Lower, Stop

NOTES

1. Zones and areas are created and configured using Lutron's ESN Configuration Tool on an iPhone® or iPod touch® mobile device, or the Quantum® Q-Design™ Tool. Only those areas and zones which have been configured using one of these tools are accessible through integration.
2. Assigned zones can be given an individual Integration ID and controlled using the #OUTPUT command. For more details on setting the output Integration ID of a zone component, see the Integration Access Point section of the system that contains the ESN.
3. When the ESN is part of a *Quantum* system, then the #AREA and #OUTPUT commands found in the *Quantum* "System Commands" section of this integration document should be used.

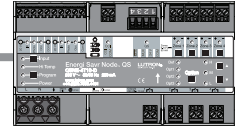

Energizer Node™ QS for International 0-10V / Switching DEVICE Commands (continued)

DEVICE Command-specific fields

- **Action Numbers and Parameters:**

Action	Action Number	Parameters
Set Current Scene	7	Scene
Set Light Level	14	Level = 0–100 or 0.00–100.00, Fade in SS.ss ¹ , SS, MM:SS, or HH:MM:SS ² Delay ³ in SS.ss ¹ , SS, MM:SS, or HH:MM:SS ²
Raise	18	None
Lower	19	None
Stop	20	None

NOTES

1. Fractional seconds “SS.ss” will be rounded down to the nearest quarter second. For example, if a fade time is specified as 1.31 seconds a value of 1.25 seconds will be used.
2. The Fade and Delay time are optional. When not used, the system will use a one second fade time with zero second delay.
3. Not supported in QS Standalone.

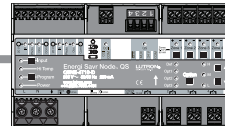

Energi Savr Node™ QS for International 0-10V / Switching OUTPUT Commands

OUTPUT Command Format

Operation *Integration ID (example)*
#OUTPUT, 1, Action Number, Parameters
Command *Use "OUTPUT Command-specific fields" tables to complete these command fields.*

OUTPUT Command-specific fields

- Action Numbers and Parameters:**

Action	Action Number	Parameters
Set or Get Zone Level	1	Level = 0–100 or 0.00–100.00, Fade in SS.ss ¹ , SS, MM:SS, or HH:MM:SS ² Delay ³ in SS.ss ¹ , SS, MM:SS, or HH:MM:SS ²
Start Raising	2	None
Start Lowering	3	None
Stop Raising/Lowering	4	None

Example OUTPUT Commands

Operation	Command String
Execute: #OUTPUT, Integration ID, Action Number, Parameters	
Set dimmer to 75% with a 1 min 30 sec fade.	#OUTPUT,1,1,75,01:30<CR><LF>
Start Raising zone level.	#OUTPUT,1,2<CR><LF>
Stop Raising/Lowering zone level.	#OUTPUT,1,4<CR><LF>
Query: ?OUTPUT, Integration ID, Action Number	
What is the state of the output?	?OUTPUT,1,1<CR><LF>
Response⁴: ~OUTPUT, Integration ID, Action Number, Parameters	
Output level is set to 90%.	~OUTPUT,1,1,90.00<CR><LF>

NOTES

- Fractional seconds “SS.ss” will be rounded down to the nearest quarter second. For example, if a fade time is specified as 1.31 seconds a value of 1.25 seconds will be used.
- The Fade and Delay time are optional. When not used the system will use a one second fade time with zero second delay.
- Not supported in QS Standalone.
- The system will report the target level of a dimmer while it is fading from one level to another. The actual level is not transmitted while dimming between levels.
Example: If the “Over Sink” (Integration ID - 1) dimmer is at 20% and is then commanded to go to 100% by sending #OUTPUT, 1, 1, 100 the response from the system will be ~OUTPUT, 1, 1, 100.00

Energi Savr Node™ with EcoSystem®

Model: QSN-2ECO-S

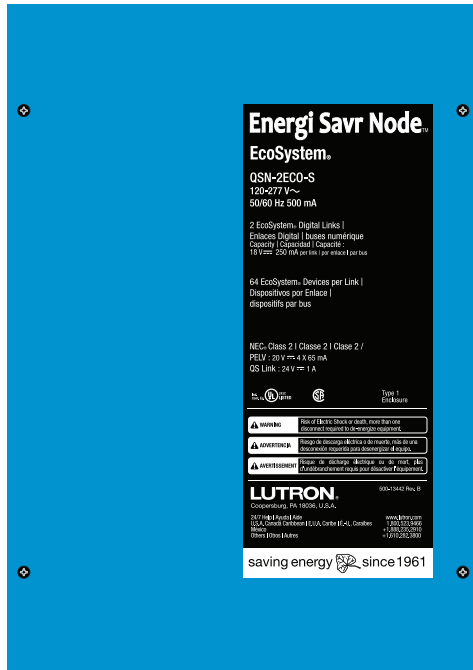

Why Integrate with an Energi Savr Node™ (ESN) with EcoSystem®?

- Control individual zones and scenes in an area
- Query current scene and light levels

Integration Capabilities

- Up to 100 areas with 16 scenes per area. Up to 100 zones across the two *EcoSystem* loops.

Supported Command Types

- **DEVICE** allows control and monitoring of zone levels and area scenes.
- **OUTPUT** allows control and monitoring of the dimmer device output.

Compatibility

	Stanza®	QS Standalone	Quantum®	RadioRA® 2
<i>EcoSystem</i> ESN		✓	✓	



Energi Savr Node™ with EcoSystem®

DEVICE Commands

DEVICE Command Formats

Operation *Integration ID (example)*
#DEVICE, 5, Component Number, Action Number, Parameters
Command Use "DEVICE Command-specific fields" tables
 to complete these command fields.

DEVICE Command-specific fields

• **Action Numbers** and **Parameters:**

Component	Component Number	Available Actions
Zone 1 – Zone 100 ^{1,2,3}	1001 – 1100	Set or Get Light Level, Raise, Lower, Stop
Area 1 – Area 100 ^{1,3}	1201 – 1300	Set or Get Scene, Set Light Level, Raise, Lower, Stop

NOTES

1. Zones and areas are created and configured using Lutron's ESN Configuration Tool on an iPhone® or iPod touch® mobile device, or the Quantum® Q-Design™ Tool. Only those areas and zones which have been configured using one of these tools are accessible through integration.
2. Assigned zones can be given an individual Integration ID and controlled using the #OUTPUT command. For more details on setting the output Integration ID of a zone component, see the Integration Access Point section of the system that contains the ESN.
3. When the ESN is part of a Quantum system, then the #AREA and #OUTPUT commands found in the Quantum "System Commands" section of this integration document should be used.



Energi Savr Node™ with EcoSystem® DEVICE Commands (continued)

DEVICE Command-specific fields

- **Action Numbers** and **Parameters:**

Action	Action Number	Parameters
Set Current Scene	7	Scene
Set Light Level	14	Level = 0–100 or 0.00–100.00, Fade in SS.ss ¹ , SS, MM:SS, or HH:MM:SS ² Delay ³ in SS.ss ¹ , SS, MM:SS, or HH:MM:SS ²
Raise	18	None
Lower	19	None
Stop	20	None

NOTES

1. Fractional seconds “SS.ss” will be rounded down to the nearest quarter second. For example, if a fade time is specified as 1.31 seconds a value of 1.25 seconds will be used.
2. The Fade and Delay time are optional. When not used, the system will use a one second fade time with zero second delay.
3. Not supported in QS Standalone.



Energi Savr Node™ with EcoSystem® OUTPUT Commands

OUTPUT Command Format

$\begin{matrix} \text{Operation} & \text{Integration ID (example)} \\ \downarrow & \downarrow \\ \#OUTPUT, 1, & \text{Action Number, Parameters} \\ \downarrow & \downarrow \\ \text{Command} & \text{Use "OUTPUT Command-specific fields" tables} \\ & \text{to complete these command fields.} \end{matrix}$

OUTPUT Command-specific fields

- Action Numbers and Parameters:**

Action	Action Number	Parameters
Set or Get Zone Level	1	Level = 0–100 or 0.00–100.00, Fade in SS.ss ¹ , SS, MM:SS, or HH:MM:SS ² Delay ³ in SS.ss ¹ , SS, MM:SS, or HH:MM:SS ²
Start Raising	2	None
Start Lowering	3	None
Stop Raising/Lowering	4	None

Example OUTPUT Commands

Operation	Command String
Execute: #OUTPUT, Integration ID, Action Number, Parameters	
Set dimmer to 75% with a 1 min 30 sec fade.	#OUTPUT,1,1,75,01:30<CR><LF>
Start Raising zone level.	#OUTPUT,1,2<CR><LF>
Stop Raising/Lowering zone level.	#OUTPUT,1,4<CR><LF>
Query: ?OUTPUT, Integration ID, Action Number	
What is the state of the output?	?OUTPUT,1,1<CR><LF>
Response⁴: ~OUTPUT, Integration ID, Action Number, Parameters	
Output level is set to 90%.	~OUTPUT,1,1,90.00<CR><LF>

NOTES

- Fractional seconds “SS.ss” will be rounded down to the nearest quarter second. For example, if a fade time is specified as 1.31 seconds a value of 1.25 seconds will be used.
- The Fade and Delay time are optional. When not used the system will use a one second fade time with zero second delay.
- Not supported in QS Standalone.
- The system will report the target level of a dimmer while it is fading from one level to another. The actual level is not transmitted while dimming between levels.
Example: If the “Over Sink” (Integration ID - 1) dimmer is at 20% and is then commanded to go to 100% by sending #OUTPUT, 1, 1, 100 the response from the system will be ~OUTPUT, 1, 1, 100.00

Energi Savr Node™ for 0-10V / Switching

Models: QSN-4T16-S, QSN-4S16-S

QSN-4T16-S

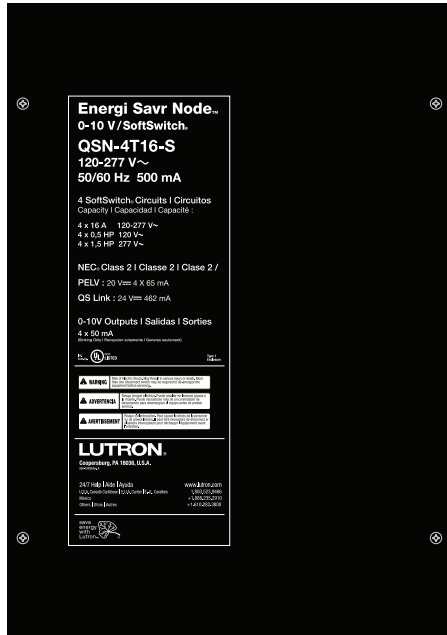

QSN-4S16-S



Why Integrate with an Energi Savr Node™ (ESN)?

- Control individual zones and scenes in an area
- Query current scene and light levels

Integration Capabilities

- Four areas with 16 scenes per area. Four zones on four independent outputs

Supported Command Types

- **DEVICE** allows control and monitoring of zone levels and area scenes.
- **OUTPUT** allows control and monitoring of the dimmer device output.

Compatibility

	Stanza®	QS Standalone	Quantum®	RadioRA® 2
ESN 0-10V/Switching		✓	✓	



Energi Savr Node™ for 0-10V / Switching DEVICE Commands

DEVICE Command Formats

Operation *Integration ID (example)*
#DEVICE, 5, Component Number, Action Number, Parameters
Command Use "DEVICE Command-specific fields" tables
 to complete these command fields.

DEVICE Command-specific fields

• **Action Numbers** and **Parameters:**

Component	Component Number	Available Actions
Zone 1 – Zone 4 ^{1,2,3}	5 – 8	Set or Get Light Level, Raise, Lower, Stop
Area 1 – Area 4 ^{1,3}	10 – 13	Set or Get Scene, Set Light Level, Raise, Lower, Stop

NOTES

1. Zones and areas are created and configured using Lutron's ESN Configuration Tool on an iPhone® or iPod touch® mobile device, or the Quantum® Q-Design™ Tool. Only those areas and zones which have been configured using one of these tools are accessible through integration.
2. Assigned zones can be given an individual Integration ID and controlled using the #OUTPUT command. For more details on setting the output Integration ID of a zone component, see the Integration Access Point section of the system that contains the ESN.
3. When the ESN is part of a *Quantum* system, then the #AREA and #OUTPUT commands found in the *Quantum* "System Commands" section of this integration document should be used.



Energi Savr Node™ for 0-10V / Switching DEVICE Commands (continued)

DEVICE Command-specific fields

- **Action Numbers** and **Parameters:**

Action	Action Number	Parameters
Set Current Scene	7	Scene
Set Light Level	14	Level = 0–100 or 0.00–100.00, Fade in SS.ss ¹ , SS, MM:SS, or HH:MM:SS ² Delay ³ in SS.ss ¹ , SS, MM:SS, or HH:MM:SS ²
Raise	18	None
Lower	19	None
Stop	20	None

NOTES

1. Fractional seconds “SS.ss” will be rounded down to the nearest quarter second. For example, if a fade time is specified as 1.31 seconds a value of 1.25 seconds will be used.
2. The Fade and Delay time are optional. When not used, the system will use a one second fade time with zero second delay.
3. Not supported in QS Standalone.



Energi Savr Node™ for 0-10V / Switching OUTPUT Commands

OUTPUT Command Format

Operation *Integration ID (example)*
#OUTPUT, 1, Action Number, Parameters
Command *Use "OUTPUT Command-specific fields" tables to complete these command fields.*

OUTPUT Command-specific fields

- Action Numbers** and **Parameters:**

Action	Action Number	Parameters
Set or Get Zone Level	1	Level = 0–100 or 0.00–100.00, Fade in SS.ss ¹ , SS, MM:SS, or HH:MM:SS ² Delay ³ in SS.ss ¹ , SS, MM:SS, or HH:MM:SS ²
Start Raising	2	None
Start Lowering	3	None
Stop Raising/Lowering	4	None

Example OUTPUT Commands

Operation	Command String
Execute: #OUTPUT, Integration ID, Action Number, Parameters	
Set dimmer to 75% with a 1 min 30 sec fade.	#OUTPUT,1,1,75,01:30<CR><LF>
Start Raising zone level.	#OUTPUT,1,2<CR><LF>
Stop Raising/Lowering zone level.	#OUTPUT,1,4<CR><LF>
Query: ?OUTPUT, Integration ID, Action Number	
What is the state of the output?	?OUTPUT,1,1<CR><LF>
Response⁴: ~OUTPUT, Integration ID, Action Number, Parameters	
Output level is set to 90%.	~OUTPUT,1,1,90.00<CR><LF>

NOTES

- Fractional seconds "SS.ss" will be rounded down to the nearest quarter second. For example, if a fade time is specified as 1.31 seconds a value of 1.25 seconds will be used.
- The Fade and Delay time are optional. When not used the system will use a one second fade time with zero second delay.
- Not supported in QS Standalone.
- The system will report the target level of a dimmer while it is fading from one level to another. The actual level is not transmitted while dimming between levels.
Example: If the "Over Sink" (Integration ID - 1) dimmer is at 20% and is then commanded to go to 100% by sending #OUTPUT, 1, 1, 100 the response from the system will be ~OUTPUT, 1, 1, 100.00

seeTouch® Keypads

QS Models (QSW2-): 1B, 1RLD, 2B, 2BRL, 2BRLIR, 2RLD, 3B, 3BD, 3BRL, 3BRLIR, 5B, 5BRL, 5BRLIR, 7B

RadioRA® 2 Models (RRD-W): 1RLD, 2RLD, 3BD, 3BRL, 5BRLIR, 6BRL, 7B

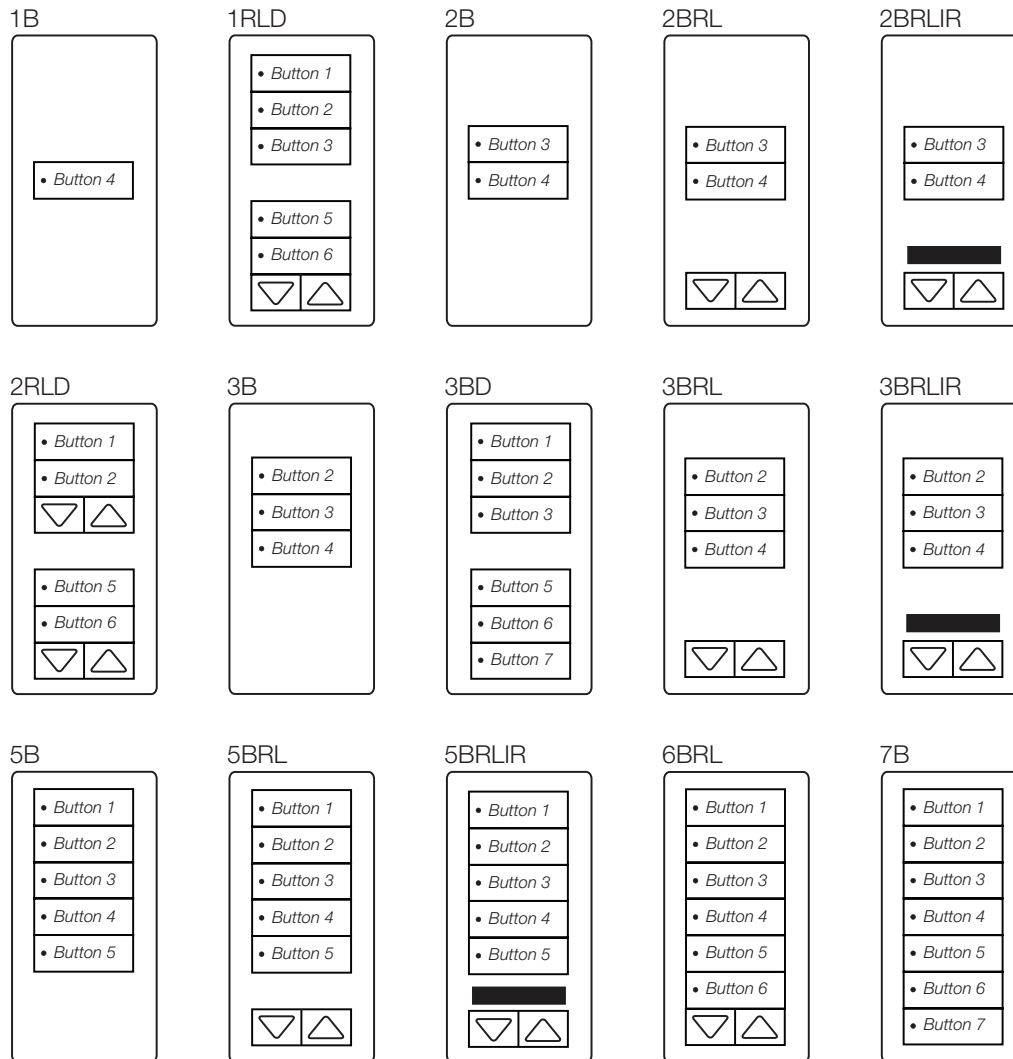

Why Integrate with a Keypad?

- Simulate a button press
- Control LEDs of unprogrammed buttons

Compatibility

seeTouch Keypads	Stanza®	QS Standalone	Quantum®	RadioRA 2
QS Models		✓	✓	
RadioRA 2 Models				✓

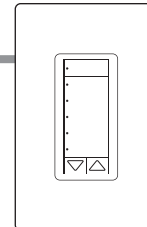

seeTouch® Keypads: DEVICE Commands

DEVICE Command Formats

Operation *Integration ID (example)*
#DEVICE, 2, Component Number, Action Number, Parameters
Command Use "DEVICE Command-specific fields" tables
 to complete these command fields.

DEVICE Command-specific fields

- Component Number:**

Component	Component Number	Available Actions
Button 1	1	Press, Release
Button 2	2	Press, Release
Button 3	3	Press, Release
Button 4	4	Press, Release
Button 5	5	Press, Release
Button 6	6	Press, Release
Button 7	7	Press, Release
Button Top Lower	16	Press, Release
Button Top Raise	17	Press, Release
Button Bottom Lower	18	Press, Release
Button Bottom Raise	19	Press, Release
CCI 2 ¹	25	Press, Release
CCI 1 ¹	26	Press, Release
LED 1	81	Set or Get LED state
LED 2	82	Set or Get LED state
LED 3	83	Set or Get LED state
LED 4	84	Set or Get LED state
LED 5	85	Set or Get LED state
LED 6	86	Set or Get LED state
LED 7	87	Set or Get LED state

NOTE

¹ Only available on seeTouch QS units with Quantum®.

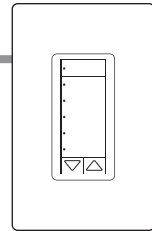

seeTouch® Keypads: DEVICE Commands

- Action Numbers and Parameters:**

Action	Action Number	Parameters
Press	3	None
Release	4	None
Hold	5	None ¹
Multi-tap	6	None ¹
Set (#) or Get (?) LED State ²	9	0=Off 1=On 2=Normal-Flash: 1 flash every second ¹ 3=Rapid-Flash: 10 flashes every second ¹

Example DEVICE Commands

Examples presume keypad has been assigned Integration ID 2.

Operation	Command String
Execute: #DEVICE, Integration ID, Component Number, Action Number, Parameters	
Press Button 1.	#DEVICE,2,1,3<CR><LF>
Turn on LED 5.	#DEVICE,2,85,9,1<CR><LF>
Query: ?DEVICE, Integration ID, Component Number, Action Number	
What is the state of LED 1?	?DEVICE,2,81,9<CR><LF>
Response: ~DEVICE, Integration ID, Component Number, Action Number, Parameters	
LED 1 is on.	~DEVICE,2,81,9,1<CR><LF>

NOTES

- ¹ Only available on *seeTouch* QS units with Quantum®.
- ² *Quantum* only. Set is for unprogrammed buttons only.

seeTouch® QS International Keypads

QS Models (QSWE-): 2B, 3B, 4B, 5BRL, 5BRLIR, 6BRL, 7BRL, 8BRL, 8BRLIR, 10BRL

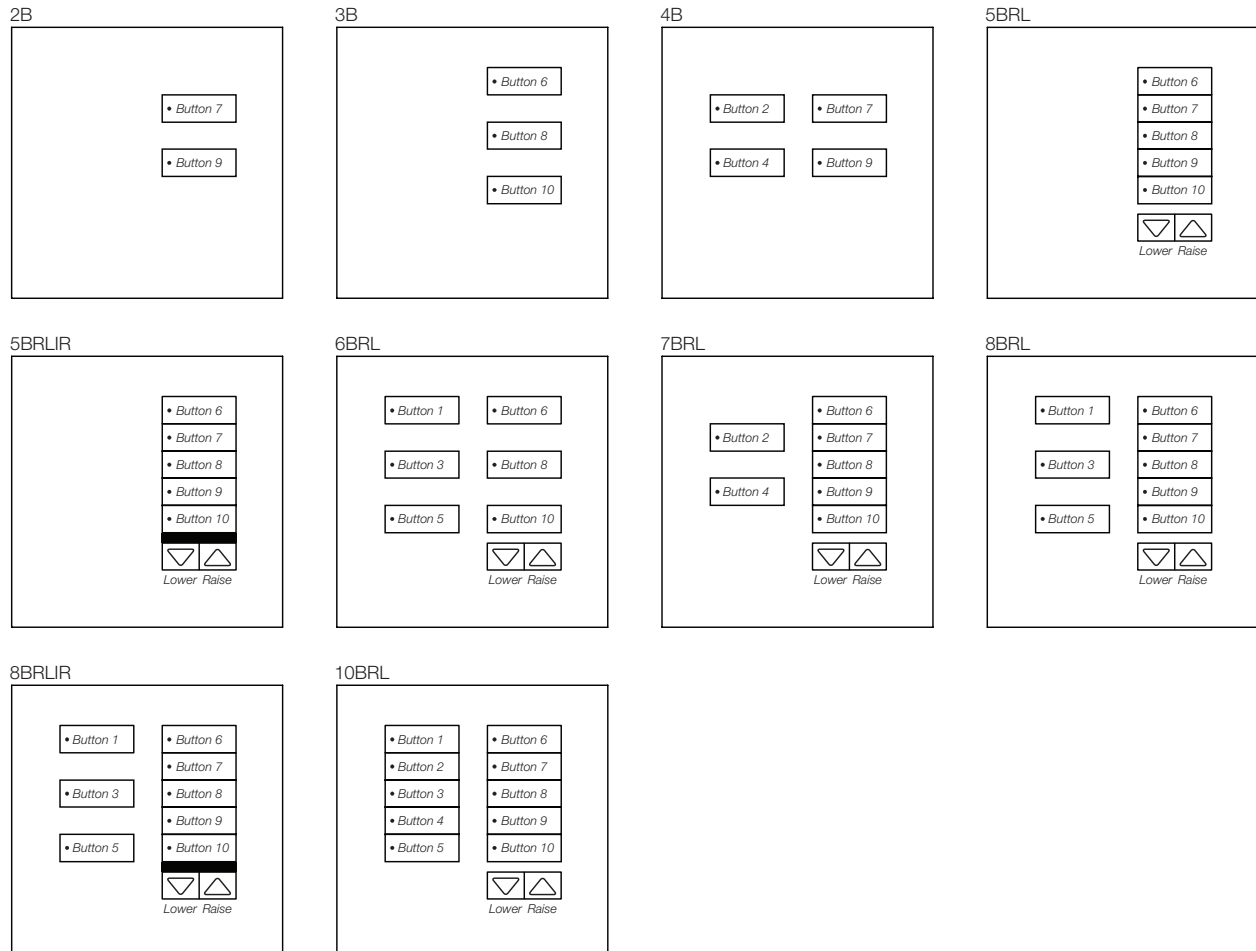

Why Integrate with a Keypad?

- Simulate a button press
- Control LEDs of unprogrammed buttons

Compatibility

seeTouch Keypads	Stanza®	QS Standalone	Quantum®	RadioRA 2
QS Models		✓	✓	

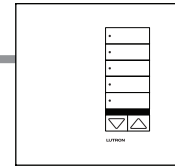

seeTouch® QS International Keypads: DEVICE Commands

DEVICE Command Formats

Operation *Integration ID (example)*
#DEVICE, 2, Component Number, Action Number, Parameters
Command *Use "DEVICE Command-specific fields" tables to complete these command fields.*

DEVICE Command-specific fields

- Component Number:**

Component	Component Number	Available Actions
Button 1	1	Press, Release
Button 2	2	Press, Release
Button 3	3	Press, Release
Button 4	4	Press, Release
Button 5	5	Press, Release
Button 6	6	Press, Release
Button 7	7	Press, Release
Button 8	8	Press, Release
Button 9	9	Press, Release
Button 10	10	Press, Release
Button Bottom Lower	18	Press, Release
Button Bottom Raise	19	Press, Release
CCI 2 ¹	25	Press, Release
CCI 1 ¹	26	Press, Release
LED 1	81	Set or Get LED state
LED 2	82	Set or Get LED state
LED 3	83	Set or Get LED state
LED 4	84	Set or Get LED state
LED 5	85	Set or Get LED state
LED 6	86	Set or Get LED state
LED 7	87	Set or Get LED state
LED 8	88	Set or Get LED state
LED 9	89	Set or Get LED state
LED 10	90	Set or Get LED state

1. Only available on seeTouch QS units with Quantum®.

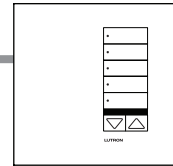

seeTouch® QS International Keypads: DEVICE Commands

- **Action Numbers and Parameters:**

Action	Action Number	Parameters
Press	3	None
Release	4	None
Hold	5	None
Multi-tap	6	None
Set (#) or Get (?) LED State ¹	9	0=Off 1=On 2=Normal-Flash: 1 flash every sec 3=Rapid-Flash: 10 flashes every sec

Example DEVICE Commands

Examples presume keypad has been assigned Integration ID 2.

Operation	Command String
Execute: #DEVICE, Integration ID, Component Number, Action Number, Parameters	
Press Button 1.	#DEVICE,2,1,3<CR><LF>
Turn on LED 5.	#DEVICE,2,85,9,1<CR><LF>
Query: ?DEVICE, Integration ID, Component Number, Action Number	
What is the state of LED 1?	?DEVICE,2,81,9<CR><LF>
Response: ~DEVICE, Integration ID, Component Number, Action Number, Parameters	
LED 1 is on.	~DEVICE,2,81,9,1<CR><LF>

NOTE

¹ Only available on seeTouch QS units with Quantum®. Set is for unprogrammed buttons only.

Sivoia® QS Shades / Sivoia® QS RF Shades

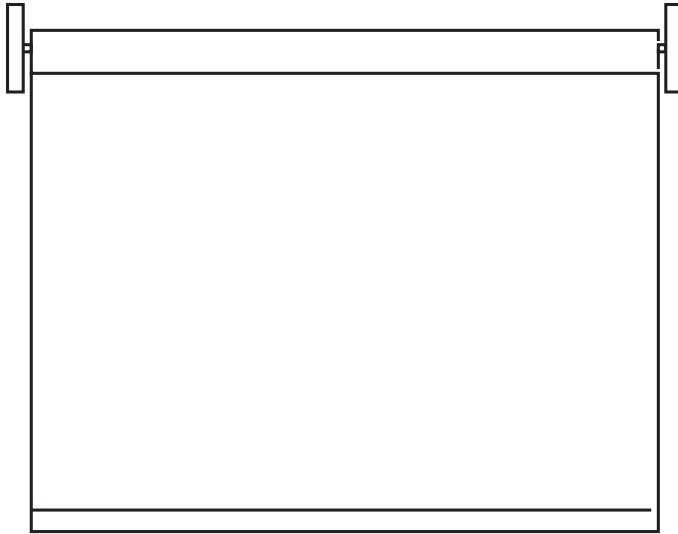

Why Integrate with Sivoia QS Shades?

- Set shades to a specific level
- Query current level

Integration Capabilities

- One controllable output (use OUTPUT command)
- To use a Sivoia QS shade with supported Lutron Wireless systems a Sivoia QS Wireless Receiver (p/n QSYC4-RCVR) is required

Supported Command Types

- **OUTPUT** allows control and monitoring of the shade output.

Compatibility

	Stanza®	QS Standalone	Quantum®	RadioRA® 2
Sivoia QS		✓	✓	✓*

*Only works with RF shades.

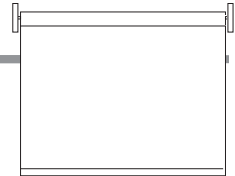

Sivoia® QS Shades: OUTPUT Commands

OUTPUT Command Format

$\begin{matrix} \text{Operation} & \text{Integration ID (example)} \\ | & | \\ \# \text{OUTPUT}, 1, & \text{Action Number, Parameters} \\ | & | \\ \text{Command} & \text{Use "OUTPUT Command-specific fields" tables} \\ & \text{to complete these command fields.} \end{matrix}$

OUTPUT Command-specific fields

Action Numbers and Parameters:

Action	Action Number	Parameters
Set (#) or Get (?) Zone Level	1	Level ² = 0–100 or 0.00–100.00, ¹ Fade ³ in SS.ss ⁴ , SS, MM:SS, or HH:MM:SS Delay ⁵ in SS.ss ⁴ , SS, MM:SS, or HH:MM:SS
Start Raising	2	None
Start Lowering	3	None
Stop Raising/Lowering	4	None

Example OUTPUT Messages

Examples presume shade has been assigned Integration ID 1.

Operation	Command String
Execute: #OUTPUT, Integration ID, Action Number, Parameters	
Set dimmer to 75% with a 1 min 30 sec delay.	#OUTPUT,1,1,75,0,1:30<CR><LF>
Start Raising shade level.	#OUTPUT,1,2<CR><LF>
Stop Raising/Lowering shade level.	#OUTPUT,1,4<CR><LF>
Query: ?OUTPUT, Integration ID, Action Number	
What is the state of the output?	?OUTPUT,1,1<CR><LF>
Response⁶: ~OUTPUT, Integration ID, Action Number, Parameters	
Output level is set to 90%.	~OUTPUT,1,1,90.00<CR><LF>

NOTES

- 0% = Closed; 100% = Open
- For shades, a level of 0 (or 0.00) equals closed and a level of 100 (or 100.00) equals full open.
- Fade is not available for shades since they move at a constant rate. The parameter must be entered but is ignored.
- Fractional seconds “SS.ss” will be rounded down to the nearest quarter second. For example, if a delay time is specified as 1.45 seconds a value of 1.25 seconds will be used.
- The Delay time is optional. When not used, the system will use a zero second delay. The minimum delay time is 0.25 seconds. The maximum delay time is 4 hours. *Not supported in QS Standalone.*
- The system will report the target level of a shade. The actual level is not transmitted while they are moving.

Example: If the Living Room Blackouts (Integration ID 1) are at 20% and are commanded to go to 100% by sending #OUTPUT, 1, 1, 100 the response from the system will be ~OUTPUT, 1, 1, 100.00

Sivoia® QS Venetian Blinds / Sivoia® QS Wireless Venetian Blinds

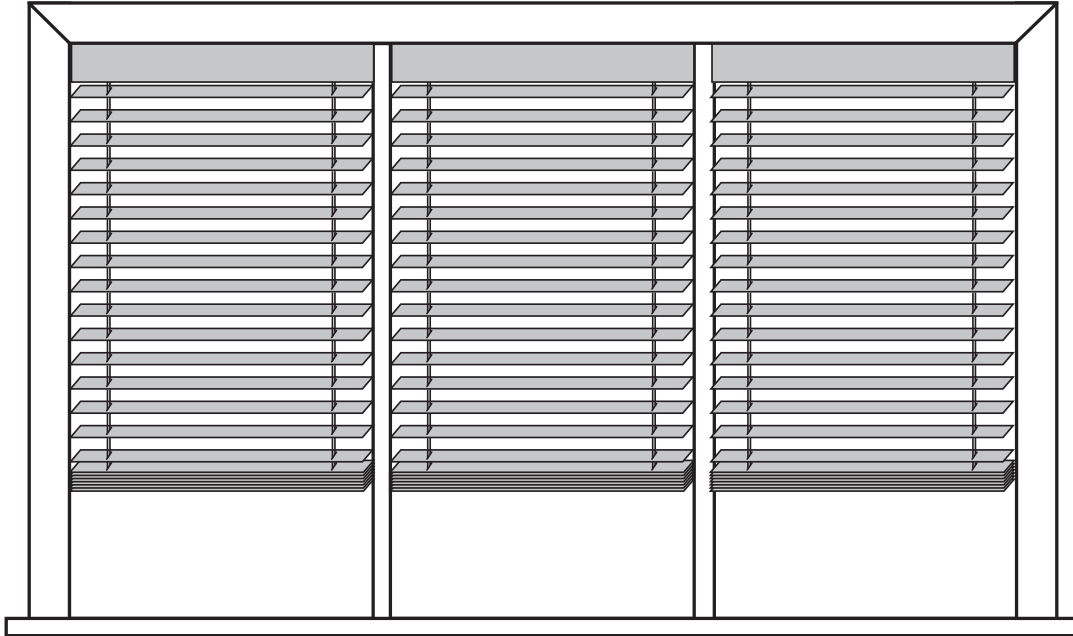

Why Integrate with Sivoia QS Venetian Blinds?

- Set Venetian blind tilt, lift to specific levels
- Query current tilt, lift levels

Integration Capabilities

- One controllable output (use OUTPUT command)
- To use a Sivoia QS Venetian blind with supported Lutron Wireless systems a Sivoia QS Wireless Receiver (p/n QSYC4-RCVR) is required

Supported Command Types

- **OUTPUT** allows control and monitoring of the Venetian blind output.

Compatibility

	Stanza®	QS Standalone	Quantum®	RadioRA® 2
Sivoia QS Venetians		✓		✓*

*Only works with RF shades.

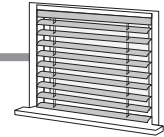

Sivoia® QS Venetian Blinds: OUTPUT Commands

OUTPUT Command Format

Operation *Integration ID (example)*
#OUTPUT, 1, Action Number, Parameters
Command Use "OUTPUT Command-specific fields" tables
 to complete these command fields.

OUTPUT Command-specific fields

Action Numbers and Parameters:

Action	Action Number	Parameters
Set (#) or Get (?) Venetian lift level only	1	Lift Level ¹ = 0–100 or 0.00–100.00 ¹ Fade ² in SS.ss ³ , SS, MM:SS, or HH:MM:SS Delay ⁴ in SS.ss ³ , SS, MM:SS, or HH:MM:SS
Set (#) or Get (?) Venetian tilt level only	9	Tilt Level ¹ = 0–100 or 0.00–100.00 ¹ Fade ² in SS.ss ³ , SS, MM:SS, or HH:MM:SS Delay ⁴ in SS.ss ³ , SS, MM:SS, or HH:MM:SS
Set (#) or Get (?) Venetian lift & tilt level	10	Lift Level ¹ = 0–100 or 0.00–100.00 ¹ Tilt Level ¹ = 0–100 or 0.00–100.00 ¹ Fade ² in SS.ss ³ , SS, MM:SS, or HH:MM:SS Delay ⁴ in SS.ss ³ , SS, MM:SS, or HH:MM:SS
Start raising Venetian tilt	11	None
Start lowering Venetian tilt	12	None
Stop Venetian tilt	13	None
Start raising Venetian lift	14	None
Start lowering Venetian lift	15	None
Stop Venetian lift	16	None

Example OUTPUT Messages

Examples presume shade has been assigned Integration ID 1.

Operation	Command String
Execute: #OUTPUT, Integration ID, Action Number, Parameters	
Set Venetian blind to lift 0%, tilt 50%	#OUTPUT,1,10,0,50<CR><LF>
Start raising Venetian tilt.	#OUTPUT,1,11<CR><LF>
Stop raising Venetian tilt.	#OUTPUT,1,13<CR><LF>
Query: ?OUTPUT, Integration ID, Action Number	
What is the state of the Venetian lift and tilt?	?OUTPUT,1,10<CR><LF>
Response⁵: ~OUTPUT, Integration ID, Action Number, Parameters	
Venetian lift level is 0%, tilt level 50%.	~OUTPUT,1,10,0.00,50.00<CR><LF>

Notes appear on following page...

Lutron® integration protocol

NOTES

	Lift		Tilt	
1.	100%		100%	
	75%		75%	
	50%		50%	
	25%		25%	
	0%		0%	

2. Fade is not available for blinds since they move at a constant rate. The parameter must be entered but is ignored.
3. Fractional seconds "SS.ss" will be rounded down to the nearest quarter second. For example, if a delay time is specified as 1.45 seconds a value of 1.25 seconds will be used.
4. The Delay time is optional. When not used, the system will use a zero second delay. The minimum delay time is 0.25 seconds. The maximum delay time is 4 hours. *Not supported in QS Standalone.*
5. The system will report the target lift level and target tilt level of a Venetian blind. The actual levels are not transmitted while it is moving.

Example: If the Kitchen Venetian (Integration ID 1) is set at 25% lift and 75% tilt, and is commanded to go to 100% lift and 50% tilt by sending #OUTPUT, 1, 10, 100, 50 the response from the system will be ~OUTPUT, 1, 10, 100.00, 50.00

Maestro® Dimmers & Plug-In Modules

RadioRA® 2 Models (dimmers): RRD-6D, RRD-6XA, RRD-8ANS, RRD-8S, RRD-10D, RRD-10ND, RRD-F6AN, RRD-3LD

RadioRA 2 Models (plug-in modules): RR-3PD, RR-15APS

RRD-6D

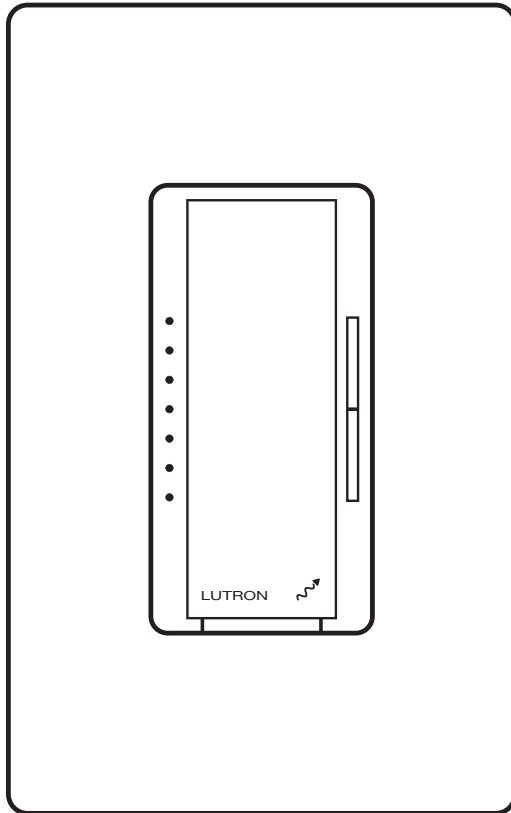

RR-3PD

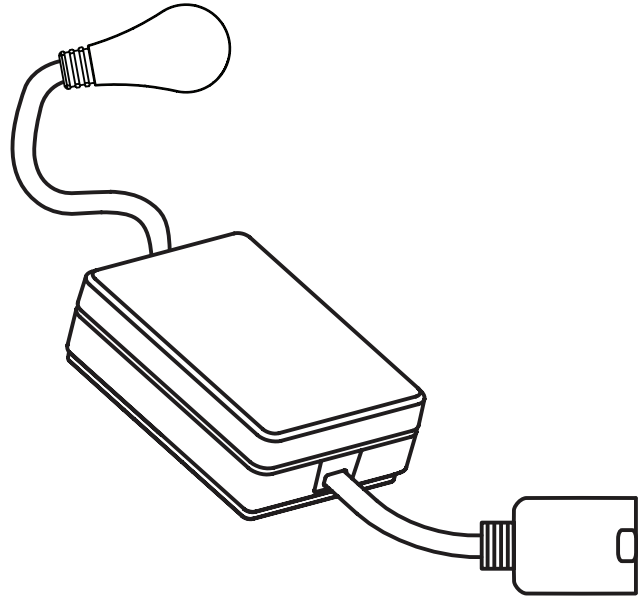

Why Integrate with a Dimmer?

- Turn on to specific light level or off
- Raise/lower light level
- Query current light level

Additional Commands

None

Compatibility

	Stanza®	QS Standalone	Quantum®	RadioRA 2
Maestro Dimmer				✓

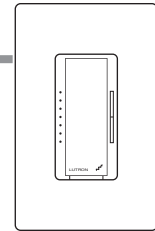

Maestro® Dimmers: OUTPUT Commands

OUTPUT Command Format

^{Operation}
^{Integration ID (example)}
#OUTPUT, 1, Action Number, Parameters
_{Command} Use "OUTPUT Command-specific fields" tables
 to complete these command fields.

OUTPUT Command-specific fields

Action Numbers and Parameters:

Action	Action Number	Parameters
Set or Get Zone Level	1	Level = 0–100 or 0.00–100.00, Fade in SS.ss ¹ , SS, MM:SS, or HH:MM:SS ² Delay in SS.ss ¹ , SS, MM:SS, or HH:MM:SS ²
Start Raising	2	None
Start Lowering	3	None
Stop Raising/Lowering	4	None

Example OUTPUT Commands

Examples presume dimmer has been assigned Integration ID 1.

Operation	Command String
Execute: #OUTPUT, Integration ID, Action Number, Parameters	
Set dimmer to 75% with a 1 min 30 sec fade.	#OUTPUT,1,1,75,01:30<CR><LF>
Start Raising dimmer level.	#OUTPUT,1,2<CR><LF>
Stop Raising/Lowering dimmer level.	#OUTPUT,1,4<CR><LF>
Query: ?OUTPUT, Integration ID, Action Number	
What is the state of the output?	?OUTPUT,1,1<CR><LF>
Response³: ~OUTPUT, Integration ID, Action Number, Parameters	
Output level is set to 90%.	~OUTPUT,1,1,90.00<CR><LF>

NOTES

- Fractional seconds "SS.ss" will be rounded down to the nearest quarter second. For example, if a fade time is specified as 1.31 seconds a value of 1.25 seconds will be used.
- The Fade and Delay time are optional. When not used the system will use a one second fade time with zero second delay.
- The system will report the target level of a dimmer while it is fading from one level to another. The actual level is not transmitted while dimming between levels.
Example: If the "Over Sink" (1) dimmer is at 20% and is then commanded to go to 100% by sending #OUTPUT, 1, 1, 100 the response from the system will be ~OUTPUT, 1, 1, 100.00

Hybrid Keypad

Model: RRD-H6BRL

RRD-H6BRL

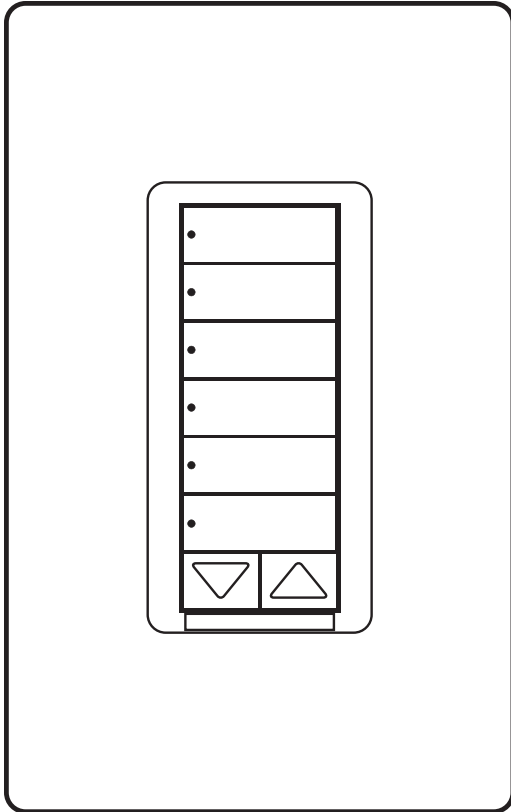

Why Integrate with a Hybrid Keypad?

- Turn on to specific light level or off
- Raise/lower light level
- Query current light level

Additional Commands

None

Compatibility

	Stanza®	QS Standalone	Quantum®	RadioRA 2
Hybrid Keypad				✓

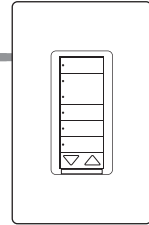

Hybrid Keypad: OUTPUT Commands

OUTPUT Command Format

^{Operation}
^{Integration ID (example)}
#OUTPUT, 1, Action Number, Parameters
_{Command} Use "OUTPUT Command-specific fields" tables to complete these command fields.

OUTPUT Command-specific fields

Action Numbers and Parameters:

Action	Action Number	Parameters
Set or Get Zone Level	1	Level = 0–100 or 0.00–100.00, Fade in SS.ss ¹ , SS, MM:SS, or HH:MM:SS ² Delay in SS.ss ¹ , SS, MM:SS, or HH:MM:SS ²
Start Raising	2	None
Start Lowering	3	None
Stop Raising/Lowering	4	None
Start Flashing ^{4,5,6}	5	Fade in SS.ss ¹ , SS, MM:SS, or HH:MM:SS ² Delay in SS.ss ¹ , SS, MM:SS, or HH:MM:SS ²

Example OUTPUT Commands

Examples presume dimmer has been assigned Integration ID 1.

Operation	Command String
Execute: #OUTPUT, Integration ID, Action Number, Parameters	
Set dimmer to 75% with a 1 min 30 sec fade.	#OUTPUT,1,1,75,01:30<CR><LF>
Start Raising dimmer level.	#OUTPUT,1,2<CR><LF>
Stop Raising/Lowering dimmer level.	#OUTPUT,1,4<CR><LF>
Start Flashing a dimmer.	#OUTPUT,1,5<CR><LF>
Start Flashing a dimmer once every 2 seconds.	#OUTPUT,1,5,1<CR><LF>
Query: ?OUTPUT, Integration ID, Action Number	
What is the state of the output?	?OUTPUT,1,1<CR><LF>
Response^{3,4}: ~OUTPUT, Integration ID, Action Number, Parameters	
Output level is set to 90%.	~OUTPUT,1,1,90.00<CR><LF>

NOTES

- Fractional seconds "SS.ss" will be rounded down to the nearest quarter second. For example, if a fade time is specified as 1.31 seconds a value of 1.25 seconds will be used.
- The Fade and Delay time are optional. When not used the system will use a one second fade time with zero second delay.
- The system will report the target level of a dimmer while it is fading from one level to another. The actual level is not transmitted while dimming between levels.
Example: If the "Over Sink" (1) dimmer is at 20% and is then commanded to go to 100% by sending #OUTPUT, 1, 1, 100 the response from the system will be ~OUTPUT, 1, 1, 100.00
- The system will not report a level while the output is flashing, it will instead report that it is flashing.
- Default flash every second, unless fade time is specified (flash period is 2x fade time).
- To stop a dimmer from flashing, send it to a valid level.

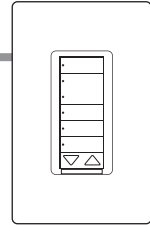

Hybrid Keypad: DEVICE Commands

DEVICE Command Formats

Operation *Integration ID (example)*
#DEVICE, 2, Component Number, Action Number, Parameters
Command *Use "DEVICE Command-specific fields" tables to complete these command fields.*

DEVICE Command-specific fields

- Component Number:**

Component	Component Number	Available Actions
Button 1	1	Press, Release
Button 2	2	Press, Release
Button 3	3	Press, Release
Button 4	4	Press, Release
Button 5	5	Press, Release
Button 6	6	Press, Release
Button 7	7	Press, Release
Button Top Lower	16	Press, Release
Button Top Raise	17	Press, Release
Button Bottom Lower	18	Press, Release
Button Bottom Raise	19	Press, Release
LED 1	81	Set or Get LED state
LED 2	82	Set or Get LED state
LED 3	83	Set or Get LED state
LED 4	84	Set or Get LED state
LED 5	85	Set or Get LED state
LED 6	86	Set or Get LED state
LED 7	87	Set or Get LED state

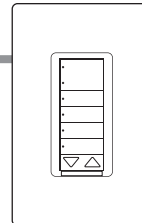

Hybrid Keypads: DEVICE Commands

- Action Numbers and Parameters:**

Action	Action Number	Parameters
Press	3	None
Release	4	None
Set (#) or Get (?) LED State	9	0=Off 1=On 2=Normal-Flash: 1 flash every second ¹ 3=Rapid-Flash: 10 flashes every second ¹
NOTE: Set is for LEDs on unprogrammed buttons only		

Example DEVICE Commands

Examples presume keypad has been assigned Integration ID 2.

Operation	Command String
Execute: #DEVICE, Integration ID, Component Number, Action Number, Parameters	
Press Button 1.	#DEVICE,2,1,3<CR><LF>
Turn on LED 5.	#DEVICE,2,85,9,1<CR><LF>
Query: ?DEVICE, Integration ID, Component Number, Action Number	
What is the state of LED 1?	?DEVICE,2,81,9<CR><LF>
Response: ~DEVICE, Integration ID, Component Number, Action Number, Parameters	
LED 1 is on.	~DEVICE,2,81,9,1<CR><LF>

Tabletop seeTouch® Keypads

RadioRA® 2 Models: RR-T5RL, RR-T10RL, RR-T15RL

T5-RL

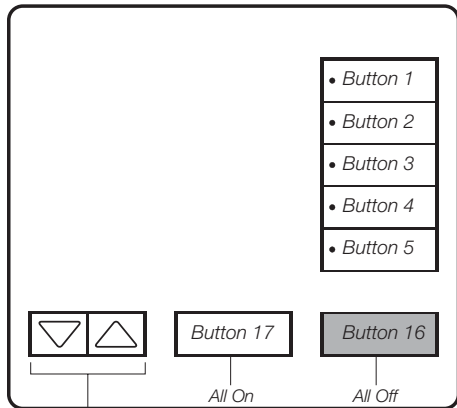

Column 3: Lower
Column 3: Raise

T10-RL

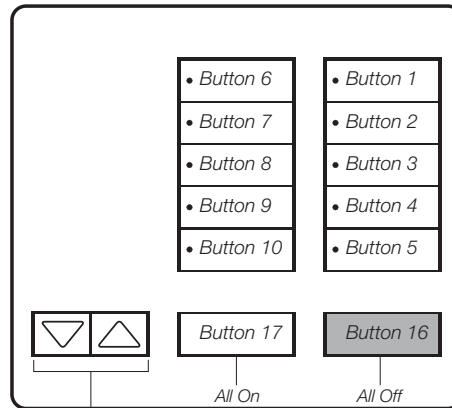

Column 3: Lower
Column 3: Raise

T15-RL

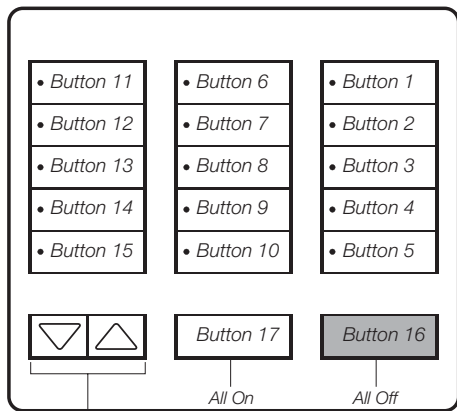

Column 3: Lower
Column 3: Raise

T15-RL

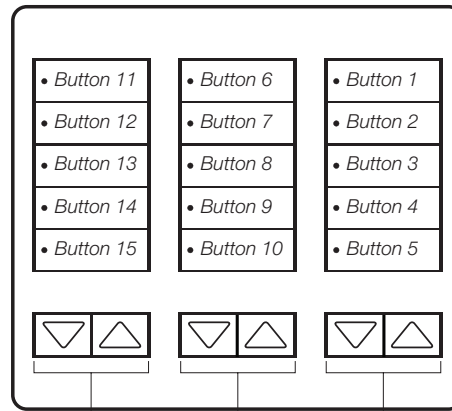

Column 3: Lower Column 2: Lower Column 1: Lower
Column 3: Raise Column 2: Raise Column 1: Raise

Why Integrate with a Tabletop Keypad?

- Simulate a button press
- Control LEDs of unprogrammed buttons

Additional Commands

None

Compatibility

	Stanza®	QS Standalone	Quantum®	RadioRA 2
Tabletop seeTouch				✓

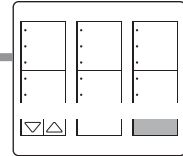

Tabletop seeTouch® Keypads: DEVICE Commands

DEVICE Command Formats

Operation *Integration ID (example)*
#DEVICE, 3, Component Number, Action Number, Parameters
Command *Use "DEVICE Command-specific fields" tables to complete these command fields.*

DEVICE Command-specific fields

- Component Number:**

Component	Component Number	Available Actions
Button 1	1	Press, Release
Button 2	2	Press, Release
Button 3	3	Press, Release
Button 4	4	Press, Release
Button 5	5	Press, Release
Button 6	6	Press, Release
Button 7	7	Press, Release
Button 8	8	Press, Release
Button 9	9	Press, Release
Button 10	10	Press, Release
Button 11	11	Press, Release
Button 12	12	Press, Release
Button 13	13	Press, Release
Button 14	14	Press, Release
Button 15	15	Press, Release
All Off	16	Press, Release
All On	17	Press, Release
Column 1: Lower	20	Press, Release
Column 1: Raise	21	Press, Release
Column 2: Lower	22	Press, Release
Column 2: Raise	23	Press, Release
Column 3: Lower	24	Press, Release
Column 3: Raise	25	Press, Release

Component numbers continued on next page...

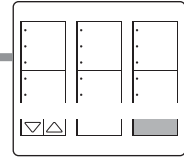

Tabletop seeTouch® Keypads:

DEVICE Commands

DEVICE Command Formats

Operation *Integration ID (example)*
#DEVICE, 3, Component Number, Action Number, Parameters
Command *Use "DEVICE Command-specific fields" tables to complete these command fields.*

- Component Number: (continued)**

Component	Component Number	Available Actions
LED 1	81	Set or Get LED state
LED 2	82	Set or Get LED state
LED 3	83	Set or Get LED state
LED 4	84	Set or Get LED state
LED 5	85	Set or Get LED state
LED 6	86	Set or Get LED state
LED 7	87	Set or Get LED state
LED 8	88	Set or Get LED state
LED 9	89	Set or Get LED state
LED 10	90	Set or Get LED state
LED 11	91	Set or Get LED state
LED 12	92	Set or Get LED state
LED 13	93	Set or Get LED state
LED 14	94	Set or Get LED state
LED 15	95	Set or Get LED state

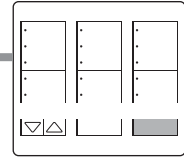

Tabletop seeTouch® Keypads: DEVICE Commands

- Actions and Parameters:**

Action	Action Number	Parameters
Press	3	None
Release	4	None
Set (#) or Get (?) LED State <i>Set is for unprogrammed LEDs only</i>	9	0=Off 1=On

Example DEVICE Commands

Examples presume keypad has been assigned Integration ID 3.

Operation	Command String
Execute: #DEVICE, Integration ID, Component Number, Action Number, Parameters	
Press Button 1.	#DEVICE,3,1,3<CR><LF>
Turn on LED 1.	#DEVICE,3,81,9,1<CR><LF>
Query: ?DEVICE, Integration ID, Component Number, Action Number	
What is the state of LED 1?	?DEVICE,3,81,9<CR><LF>
Response: ~DEVICE, Integration ID, Component Number, Action Number, Parameters	
LED 1 is on.	~DEVICE,3,81,9,1<CR><LF>

Lutron® integration protocol

Pico® wireless controls

QS Models (QSR4P-, QSR8P-, QSRKP-, QSRMP-): 2, 2R, 3R

RadioRA® 2 Models (RRD-P): 3BRL-L, 3BRL-S

Maestro® RF Models (MRF2-): 2B, 2BRL, 3B, 3BRL

Stanza® Models (SZR-): 1, 2, 2RL

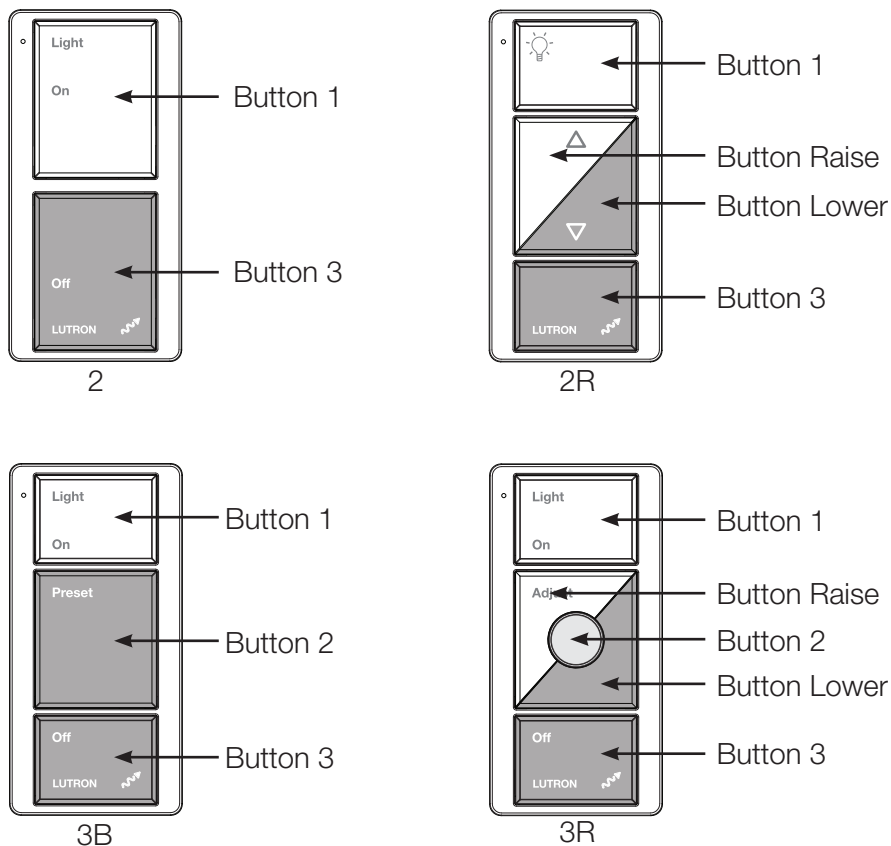

Why Integrate with a Pico Wireless Control?

- Simulate a button press
- Monitor button presses

Compatibility

	Stanza®	QS Standalone	Quantum®	RadioRA 2
QS Models *			✓ *	
RadioRA 2 Models				✓
Stanza Models	✓			

*Can only be used when associated to a QSM

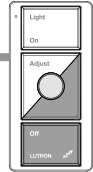

Pico® wireless controls: DEVICE Commands

DEVICE Command Formats

Operation *Integration ID (example)*
#DEVICE, 2, Component Number, Action Number, Parameters
Command Use "DEVICE Command-specific fields" tables
 to complete these command fields.

DEVICE Command-specific fields

- Component Number:**

Component	Component Number	Available Actions
Button 1	2	Press, Release
Button 2	3	Press, Release
Button 3	4	Press, Release
Button Raise	5	Press, Release
Button Lower	6	Press, Release

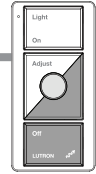

Pico® wireless controls: DEVICE Commands

- **Action Numbers and Parameters:**

Action	Action Number	Parameters
Press	3	None
Release	4	None

Example DEVICE Commands

Examples presume keypad has been assigned Integration ID 2.

Operation	Command String
Execute: #DEVICE, Integration ID, Component Number, Action Number, Parameters	
Press Button 1.	# <i>DEVICE</i> ,2,1,3<CR><LF>
Response: ~DEVICE, Integration ID, Component Number, Action Number, Parameters	
Button 1 was pressed.	~ <i>DEVICE</i> ,2,1,3<CR><LF>

RadioRA® 2 Visor Control Receiver

Model: RR-VCRX

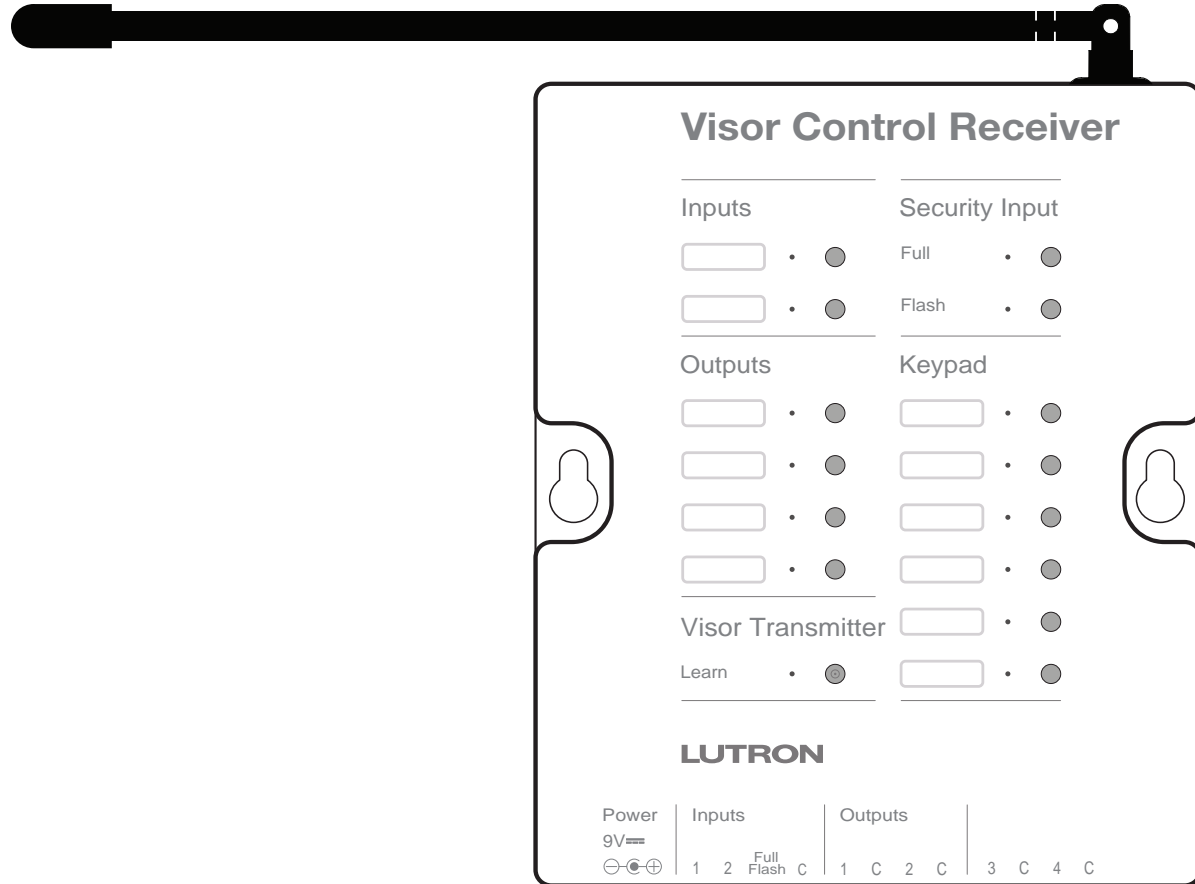

Why Integrate with a Visor Control Receiver?

- Simulate a keypad press or contact closure inputs
- Control LEDs of unprogrammed buttons
- Control contact closure outputs

Additional Commands

None

Compatibility

	Stanza®	QS Standalone	Quantum®	RadioRA 2
Visor Control Receiver				✓

Devices

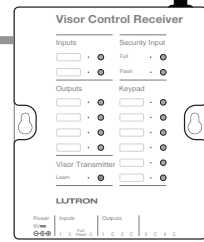

RadioRA® 2 Visor Control Receiver: DEVICE Commands

DEVICE Command Formats

Operation *Integration ID (example)*
#DEVICE, 5, Component Number, Action Number, Parameters
Command *Use "DEVICE Command-specific fields" tables to complete these command fields.*

DEVICE Command-specific fields

- Component Number:**

Component	Component Number	Available Actions
Scene 1	1	Press, Release
Scene 2	2	Press, Release
Scene 3	3	Press, Release
Scene 4	4	Press, Release
Scene 5	5	Press, Release
Scene 6	6	Press, Release
Security Full	30	Open Input, Close Input
Security Flash	31	Open Input, Close Input
Input 1	32	Open Input, Close Input
Input 2	33	Open Input, Close Input
LED Scene 1	81	Set or Get LED state
LED Scene 2	82	Set or Get LED state
LED Scene 3	83	Set or Get LED state
LED Scene 4	84	Set or Get LED state
LED Scene 5	85	Set or Get LED state
LED Scene 6	86	Set or Get LED state

DEVICE Command-specific fields continued on next page...

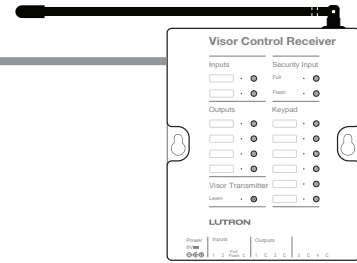

RadioRA® 2 Visor Control Receiver: DEVICE Commands

DEVICE Command Formats

^{Operation}
^{Integration ID (example)}
#DEVICE, 5, Component Number, Action Number, Parameters
_{Command} *Use "DEVICE Command-specific fields" tables to complete these command fields.*

DEVICE Command-specific fields (continued)

- Action Numbers and Parameters:**

Action	Action Number	Parameters
Press, Close Input	3	None
Release, Open Input	4	None
Set (#) or Get (?) LED State	9	0=Off 1=On
NOTE: Set is for LEDs on unprogrammed buttons only		

Example DEVICE Commands

Examples presume Visor Control Receiver has been assigned Integration ID 5.

Operation	Command String
Execute: #DEVICE, Integration ID, Component Number, Action Number, Parameters	
Press Scene 1.	#DEVICE,5,1,3<CR><LF>
Turn on Scene 1 LED.	#DEVICE,5,9,81,1<CR><LF>
Query: ?DEVICE, Integration ID, Component Number, Action Number	
What is the state of LED 1?	?DEVICE,5,9,81<CR><LF>
Response: ~DEVICE, Integration ID, Component Number, Action Number, Parameters	
LED 1 is on.	~DEVICE,5,9,81,1<CR><LF>

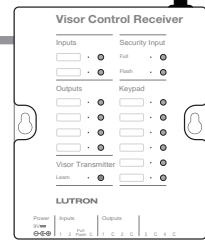

RadioRA® 2 Visor Control Receiver: OUTPUT Commands

OUTPUT Command Format

Operation Integration ID (example)

#OUTPUT,21, 1, Parameters

Command Action number is always 1 Use "OUTPUT Command-specific fields" tables
for visor control outputs to complete the parameter field.

OUTPUT Command-specific fields

Action Numbers and Parameters:

Action	Action Number	Parameters
Set (#) or Query (?) Output State	1	Level ¹ = 0–100 or 0.00–100.00,

Example OUTPUT Messages

Examples presume CCO has been assigned Integration ID 1.

Operation	Command String
Set: #OUTPUT, Integration ID, Action Number, Parameters	
Set output to open	#OUTPUT,21,1,0<CR><LF>
Set output to close	#OUTPUT,21,1,1<CR><LF>
Query: ?OUTPUT, Integration ID, Action Number	
What is the state of the output?	?OUTPUT,21,1<CR><LF>
Response: ~OUTPUT, Integration ID, Action Number	
Output state is closed	~OUTPUT,21,1,100.00<CR><LF>

NOTES

1. Any level greater than 0 will close the output. When level is equal to 0 the output will open.
2. Momentary outputs should not be queried.
3. The system will report the target level of outputs. Any level greater than 0 means that the output is closed.

Radio Powr Savr™

Models: LRF2-OCRB, LRF2-VCRB, LRF2-OKLB, LRF2-VKLB,
LRF2-OWLB, LRF2-VWLB, LRF2-OHLB, LRF2-VHLB

LRF2-OCRB

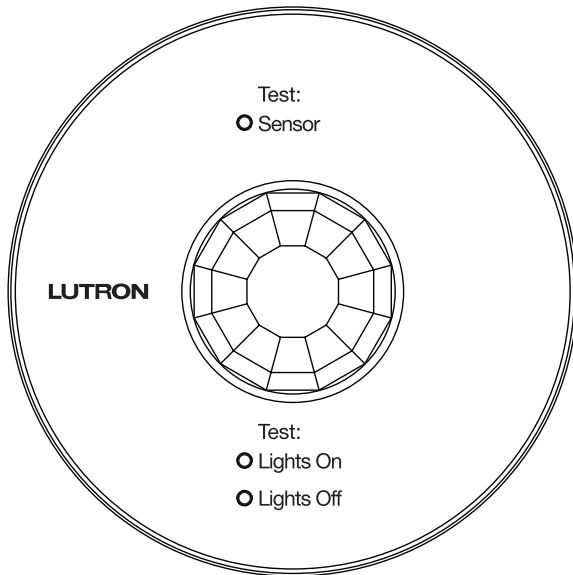

LRF2-OKLB

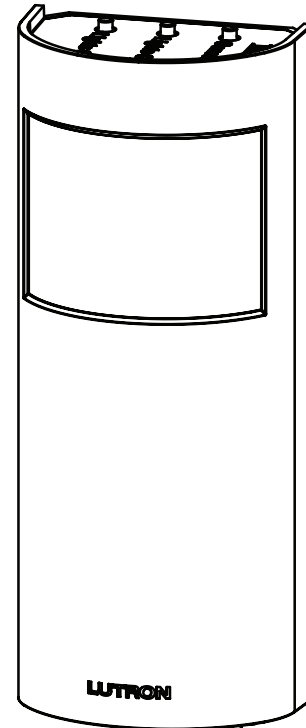

Why Integrate with a Radio Powr Savr?

- Monitor occupied, unoccupied status of a single sensor

Compatibility

	Stanza®	QS Standalone	Quantum®	RadioRA 2
Radio Powr Savr				✓

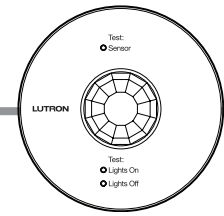

Radio Powr Savr™: DEVICE Commands

DEVICE Command Formats

Operation *Integration ID (example)*
 ~DEVICE, 19, 2, Action Number
Command *Occupied state component is always 2 for sensors*

DEVICE Command-specific fields

- Component Number:**

Component	Component Number	Available Actions
Occupied State	2	Press (occupied), Release (unoccupied)

- Action Numbers:**

Action	Action Number
Press (occupied)	3
Release (unoccupied)	4

Example DEVICE Commands

Examples presume sensor has been assigned Integration ID 19.

Operation	Command String
Response: ~DEVICE, Integration ID, Component Number, Action Number, Parameters	
Radio Powr Savr 19 went occupied.	~DEVICE, 19, 2, 3<CR><LF>
Radio Powr Savr 19 went unoccupied.	~DEVICE, 19, 2, 4<CR><LF>

Programmer's Reference Appendix - A

Integration Access Point Compatibility Matrix

	Stanza®	QS Standalone	Quantum®	RadioRA® 2
Stanza Programming Control Interface	✓			
QS Network Interface		✓	✓	
RadioRA 2 Main Repeater				✓

Device Compatibility Matrix

	Stanza	QS Standalone	Quantum	RadioRA 2
Stanza Keypad	✓			
Stanza Dimmer	✓			
Stanza Switch	✓			
Stanza Lamp Module	✓			
Stanza Input/Output Interface	✓			
Stanza Plug-In Module	✓			
GRAFIK Eye® QS		✓	✓	✓
seeTouch® QS		✓	✓	
seeTouch RadioRA 2				✓
Sivoia® QS Shade		✓	✓	✓
Maestro® Dimmers + Switches				✓
Tabletop seeTouch Keypad				✓
Visor Control Receiver				✓
Hybrid Keypad				✓
Pico® Wireless Controls				✓
Radio Powr Savr™				✓
Energi Savr Node™ QS / DALI		✓	✓	
Energi Savr Node QS / Int'l 0-10V		✓	✓	
Energi Savr Node QS / EcoSystem®		✓	✓	
Energi Savr Node QS / 0-10V		✓	✓	

Programmer's Reference Appendix - B

DEVICE Command Summary

Device integration commands allow the user to access components of the system such as a physical device. The user can activate programming via button presses, releases, etc., as well as monitor those same events as they occur in real time in the system.

DEVICE Command Formats

Operation *Integration ID (example)*
 #DEVICE, 5, Component Number, Action Number, Parameters
Command *Use "DEVICE Command-specific fields" tables*
 to complete these command fields.

DEVICE Command-specific fields

Action Numbers and Parameters:

Applicable Operations (#, ?, ~)	Action	Action Number	Parameter	Description	Format	
#, ~	Press/Close	3	None			
#, ~	Release/Open	4	None			
#, ~	Hold	5	None			
#, ~	Multi-tap	6	None			
All	Set or Get Current Scene	7	Scene			
All	Set (#) or Get (?) LED State	9	LED state	New state to set the LED	0 = Off, 1 = On 2 = Normal Flash 3 = Rapid Flash	
All	Set or Get Light Level	14	1	Level	Level that the output will fade to ¹	0 - 100 or 0.00 - 100.00
			2	Fade time (optional)	Time the output should take to get from current level to new level	seconds, seconds.fractions ² , minutes:seconds, hours:minutes:seconds
			3	Delay time (optional)	Time to wait before beginning to fade	seconds, seconds.fractions ² , minutes:seconds, hours:minutes:seconds
All	Set or Get Zone Lock	15	State	State of zone lock	0 = Off 1 = On	
All	Set or Get Scene Lock	16	State	State of scene lock	0 = Off 1 = On	
All	Set or Get Sequence State	17	State	State of the automatic sequence	0 = Off, 1 = Scenes 1-4 2 = Scenes 5-16	
#	Raise	18	None			
#	Lower	19	None			
#	Stop	20	None			

Programmer's Reference Appendix - B

OUTPUT Command Summary

Outputs are dimmers, CCOs, or other devices in a system that have a controllable output. All of these devices will accept levels from 0% to 100% and 0.00% to 100.00% with a given fade and delay time. These same commands can be monitored in real-time as they occur in the system.

OUTPUT Command Format

Operation *Integration ID (example)*
#OUTPUT, 6, Action Number, Parameters
Command *Use "OUTPUT Command-specific fields" tables to complete these command fields.*

OUTPUT Command-specific fields

Action Numbers and Parameters:

Applicable Operations (#, ?, ~)	Action	Action Number	Parameters		Description	Format
All	Set or Get Zone Level	1	1	Level	Level that the output will fade to. ¹	0 - 100 or 0.00 - 100.00
			2	Fade time (optional)	Time the output should take to get from current level to new level.	seconds, seconds.fractions ² , minutes:seconds, hours:minutes:seconds
			3	Delay time (optional)	Time to wait before beginning to fade.	seconds, seconds.fractions ² , minutes:seconds, hours:minutes:seconds
#	Raise	2	-			
#	Lower	3	-			
#	Stop	4	-			
All	Start Flash ³	5	1	Fade Time (optional)	Time the output should take to complete half a flash. Flash period is 2x the fade time.	seconds, seconds.fractions ² , minutes:seconds, hours:minutes:seconds
			2	Delay (optional)	How long to wait before beginning to flash.	seconds, minutes:seconds, hours:minutes:seconds
#, ~	Pulse	6				seconds, minutes:seconds, hours:minutes:seconds

NOTES

- For switched outputs, any non-zero level results in on or closed, 0 results in off or open.
- Fractions are rounded **up** to the closest ¼ second.
- To stop a dimmer from flashing, send it to a valid level (action 1).

Programmer's Reference Appendix - B

MONITORING Command Summary

Monitoring allows the user to configure what types of messages the system will report.

Note to Integrator: *The default values of these are set in the programming database and restored whenever the integration port is logged in. The user can temporarily change those settings to hide or show information as desired.*

MONITORING Command Formats

Operation

#MONITORING, Monitoring Type, Action Number

Command

Use "MONITORING Command-specific fields" tables to complete these command fields.

MONITORING Command-specific fields

Monitoring Type:

Operations Allowed (#, ?, ~)	Description	Monitoring Type
All	Diagnostic Monitoring	1
All	Event Monitoring	2
All	Button Monitoring	3
All	LED Monitoring	4
All	Zone Monitoring	5
All	Scene #	8
All	Reply State (if disabled, all messages FROM the integration access point will cease)	11
All	Prompt State (if disabled, the prompt will not be printed to the terminal)	12
All	Set (#) or Get (?) State of All Monitoring (except Reply and Prompt)	255

Action Numbers:

Action	Action Number
Enable	1
Disable	2

Programmer's Reference Appendix - B

ERROR Command Summary

Integration Access Points will respond with an error if an invalid command is received. See the table below for explanations of different errors.

ERROR Command Formats

Operation

~ERROR, Error Number

Command

Refer to "ERROR Command-specific fields" table

ERROR Command-specific fields

Error Number:

Description	Error Number
Parameter count mismatch	1
Object does not exist	2
Invalid action number	3
Parameter data out of range	4
Parameter data malformed	5

Worldwide Technical and Sales Assistance

If you have questions concerning the installation or operation of this product, call the Lutron Technical Support Center.

Please provide the exact model number when calling.
Model number can be found on the product packaging.
Example: SZ-CI-PRG

U.S.A., Canada, and the Caribbean: 1.800.523.9466
Other countries call: +1.610.282.3800
Fax: +1.610.282.1243

Visit us on the web at www.lutron.com

Lutron, EcoSystem, GRAFIK Eye, Quantum, Maestro, Pico, RadioRA, seeTouch, Sivoia, Stanza, and the sunburst logo are registered trademarks and Energi Savr Node, Q-Design, and Radio Powr Savr are trademarks of Lutron Electronics Co. Inc.

IEEE is a registered trademark of the Institute of Electrical and Electronics Engineers, Inc., (IEEE). This publication is not endorsed or approved by the IEEE.

iPhone and iPod touch are registered trademarks of Apple, Inc. This publication is not endorsed or approved by Apple, Inc.

