

PIEGA **User Manual**

PIEGA
SWITZERLAND

«Music. That's really the only important issue when it comes to loudspeakers...»

In our view, the superior loudspeaker is the one that does not interfere. One that adds no sound of its own. That accurately and naturally conveys what was played in the concert or recording studio. Since 1986 we have been working to perfect this ideal – with a pioneering spirit, inventiveness and exacting craftsmanship. You will now be able to hear for yourself how far we have succeeded.

By purchasing a loudspeaker from PIEGA you have expressed your trust in our company, for which we thank you very much. At the same time we assure you that you have purchased a product that is based on twenty years of R & D, and which in terms of its design represents the state of the art. We are sure that you will gain much listening enjoyment from your new Piega loudspeaker products.

Although using the loudspeakers is very straightforward, we recommend that you read the contents of this user manual carefully. It will explain how to properly connect up your new PIEGA loudspeaker products and install them for optimum results. It also provides you with some useful information that will increase your understanding of loudspeakers. But don't worry. Even apparently complicated details are explained very simply. On the last page of these instructions you will find our warranty conditions. Please also read these carefully just in case.

We wish you an enjoyable read and above all much listening enjoyment with your new PIEGA loudspeakers...!

Contents

This user manual describes how to optimally install and connect the PIEGA loudspeakers for a wide range of uses and contains some useful information on operating, caring for and maintaining your loudspeakers. It also contains instructions for unpacking and setting up the loudspeakers.

Precautions	4
Unpacking the Loudspeakers	5
Uses	6
Positioning	7
On-Wall Installation	8
Connecting the Loudspeakers	9
Running the Loudspeakers	10
Daily Use	11
Warranty Conditions	12

Precautions

Please read this user manual carefully and pay special attention to the following precautions and warnings.

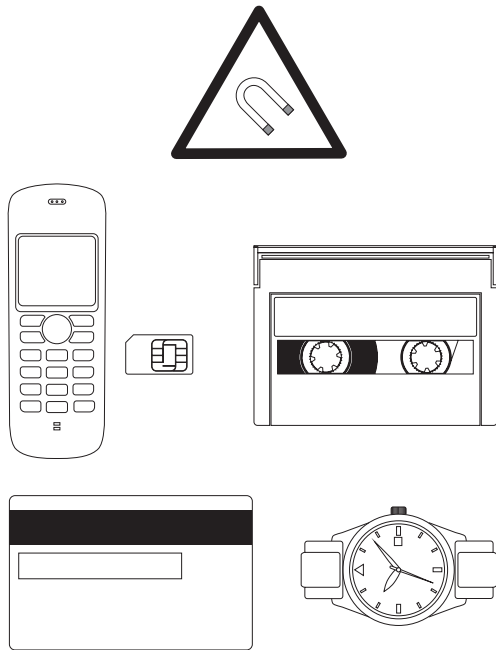

Safety Precautions:

Ensure without fail that your new PIEGA loudspeakers are mounted, positioned and connected exactly according to these instructions.

PIEGA loudspeakers were only designed for use in dry residential environments within a temperature range of 10...40°C.

The high quality loudspeaker chassis of PIEGA loudspeakers contain exceptionally strong magnets with magnetic fields that may impair the operation of other devices if the loudspeakers are not handled properly.

Ensure that watches or other metallic objects are not placed close to the loudspeakers. The strong magnetic fields may pull these into the diaphragms and destroy them.

Keep items such as credit cards, electronic data storage media and similar objects away from the loudspeakers. The magnetic field may cause irrecoverable loss of data.

Warnung:

Ensure, in particular with children, that hands are not placed inside the bass tube openings (sharp edges > risk of injury) and that objects are not inserted into these openings.

CE CONFORMS TO
UL STD. 6500
CERTIFIED TO
CAN/CSA STD. E60065



Unpacking the Loudspeakers

Special care was taken in the packaging of your new PIEGA quality products in order to ensure that your loudspeakers reach your living room safely and undamaged. In order to avoid any damage when unpacking the loudspeakers, follow closely the instructions below without fail.

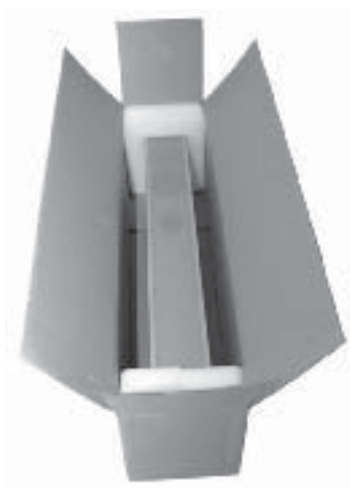

Procedure:

In order to avoid any damage when unpacking the loudspeakers or during the installation, you should always carry out the work with another person.

Before unpacking, remove any jewelry such as watches, rings, bracelets etc. in order to avoid scratching the aluminum surface.

Open the carton as shown in the figure, remove the metal brackets on the carton carefully and lift out the loudspeakers and protective cushions.

Carefully remove the protective cushions and protective wrapping by carefully pulling it up over the loudspeakers.

Check without fail that the delivery is complete, that the loudspeaker version supplied corresponds to your order, and that the loudspeakers have not been damaged in transit.

If this is the case, follow the instructions on the remaining pages or otherwise contact the dealer where you purchased the loudspeakers.

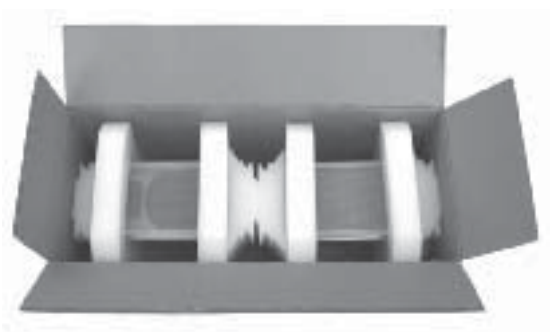

Warning:

PIEGA loudspeakers have cabinets made from polished aluminum. When unpacking, handle carefully at all times...!



Uses

The PIEGA Loudspeaker Series comprises floor-standing, satellite and center loudspeakers. Some series include all three loudspeaker types. All loudspeakers of the same series are based on the same technology, either dome tweeter or PIEGA ribbon tweeter. All loudspeakers of the same technology can always be combined and arranged into a cohesive home cinema system and also ideal for stereo systems, sound systems in bars and restaurants, fitness centers etc. We recommend....

Multi-channel system

example

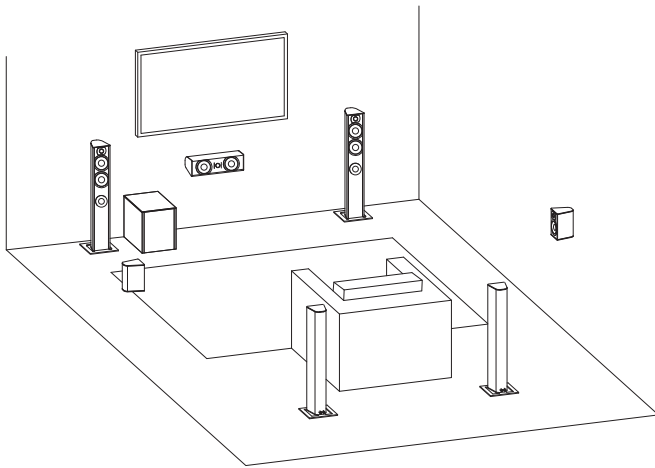

Multi-channel system

example

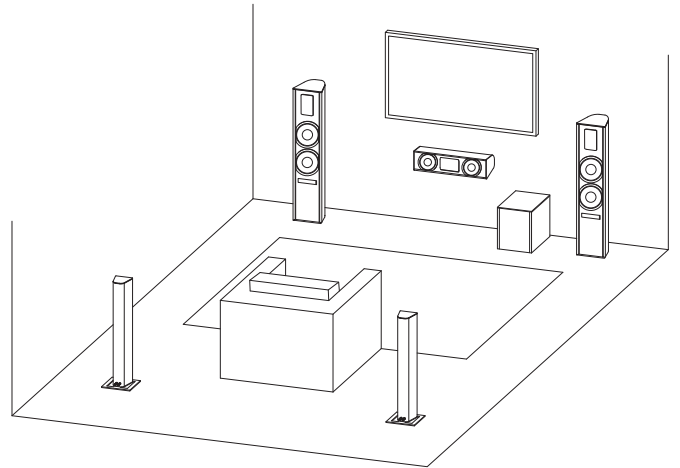

Stereo operation

example

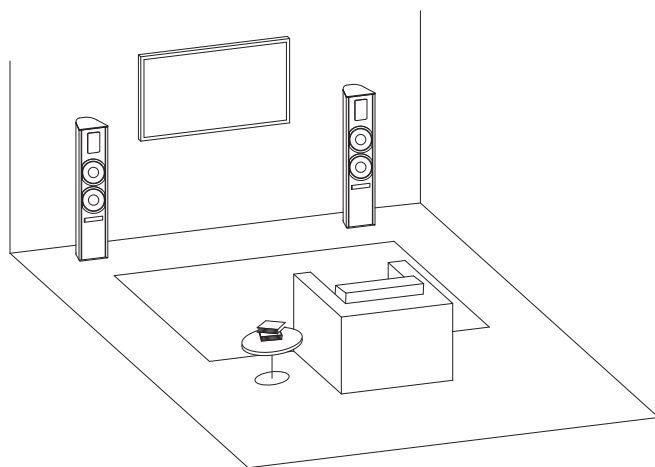

Room sound system (in bars)

example

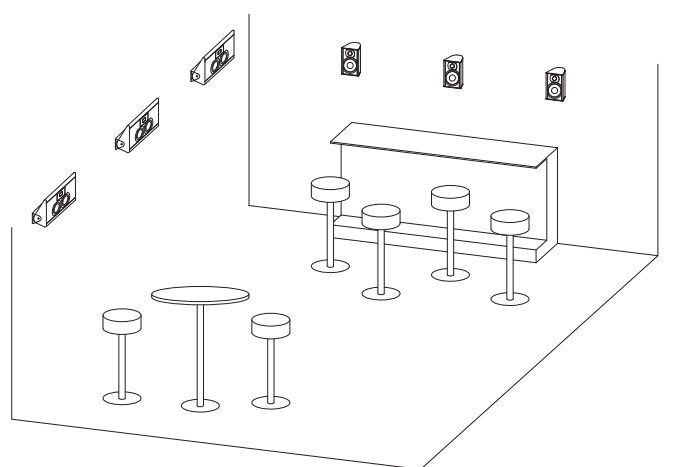

Positioning

Perfect sound quality depends on the correct positioning and alignment of the loudspeakers. For stereo operation, the best results are achieved using the stereo triangle layout. In multi-channel systems, the front, center and rear speakers should be positioned as equidistantly as possible and aligned to the point of listening and time delay should be adjusted in the setup of the AV-receiver.

Stereo operation (Stereo Triangle)

The distances between the loudspeakers and the point of listening form an isosceles triangle (Ratio 1 : 1.5).

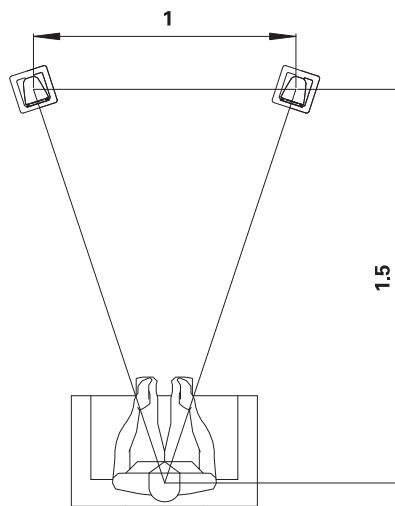

Recommended wall distance approx. 10 - 50 cm, depending on the model

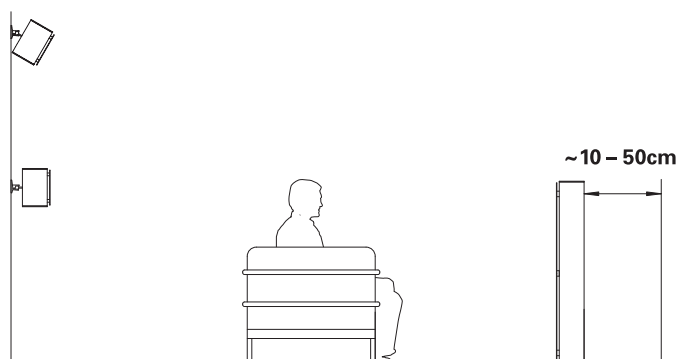

Note: For best results align the tweeter at ear level.

On-Wall Installation

You can use the wall bracket (available as an accessory) to mount the satellite loudspeakers either on the wall or ceiling and thus use it as a rear or side speaker for both diffused and direct sound. The brackets are also used when installing the loudspeakers for a room sound system. A special bracket is also available (as an accessory) for mounting the center loudspeakers on walls.

Ball-jointed wall bracket for satellite loudspeakers

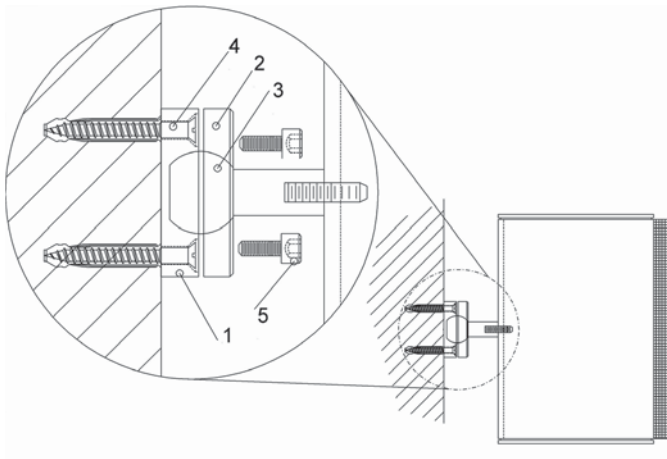

- Remove the Allen screw on the rear of the loudspeaker
- Fasten the base plate (1) to the wall with the screws (4)
- Assemble the fixing ring (2) and the ball joint and fit on the loudspeaker
- Fasten the ball joint/fixing ring onto the base plate (1) with the screws (5)
- Position the loudspeaker and fasten with the screws (5)

Wall bracket for center speakers

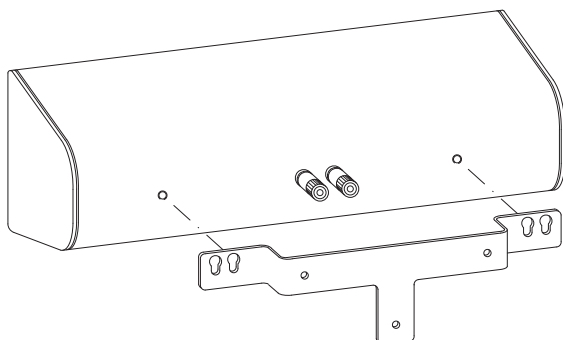

- Fasten the bracket to the wall
- Slightly unscrew the hexagon screws on the loudspeaker
- Fit the center loudspeaker on the wall bracket
- Re-tighten the hexagon screws

Note: For mounting the wall brackets consult a specialist such as your authorized PIEGA dealer if necessary.

Connecting the Loudspeakers

The terminal for single wiring applications is provided at the back of the loudspeaker. This is used for connecting standard loudspeaker cables with banana plugs or with a lead. Ideally, PIEGA loudspeakers should be connected with the CableONE or CableTHREE loudspeaker cable which is available as an accessory.

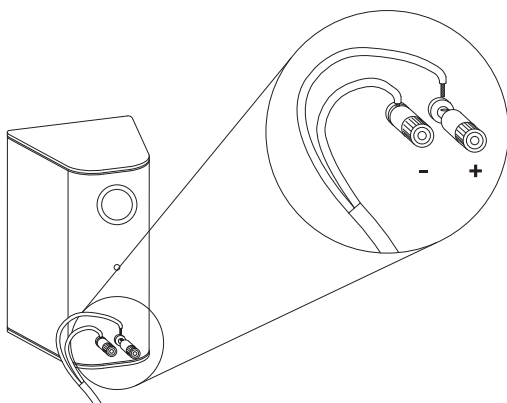

Pass the wires fully through the opening

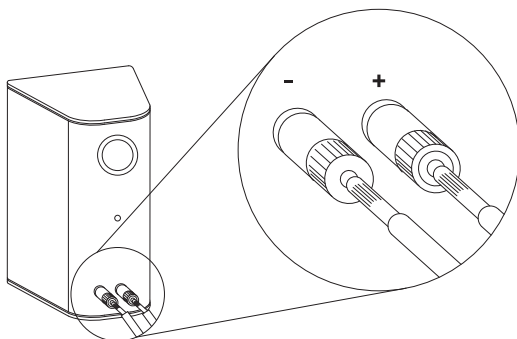

Fully insert the banana plugs up to the stop

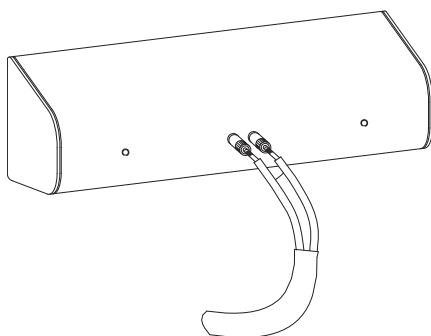

Connection:

Ensure that the electronic components are switched off before making the connection.

PIEGA loudspeakers must only be connected to electronic components with the amplifier outputs recommended by PIEGA. Observe the specifications of the amplifier manufacturer. Contact your dealer if you are unsure whether the connection is permissible.

The loudspeakers have an impedance of 4 Ohms and can therefore be connected to any standard amplifier. Contact your specialist dealer concerning this.

Connect the PIEGA loudspeaker to your amplifier or receiver using suitable cables as shown in the figure. Ideally, use the CableONE or CableTHREE loudspeaker cable (optional) with banana plugs or standard loudspeaker cables with a lead.

Important:

Ensure the poles are connected correctly! A completely diffuse sound with a weak bass will be produced if the plus and minus poles are incorrectly connected.

Active variant:

For PIEGA loudspeakers with the Active module option, please contact your retailer.

Running in the Loudspeakers

As a loudspeaker is basically a mechanical transducer consisting of several different components, the individual elements must be run in during the initial weeks. This will ensure that the sound quality potential of your loudspeakers is fully utilized. You will definitely notice the resulting improvement in sound.

Recommendations:

In the first days and weeks listen only at normal volume.

Avoid very high volume levels during initial phase.
Listen to a wide range of programme material.

Limit range:

The recommended amplifier output is, depending on the model, 20 – 250 Watt. It must be ensured that the volume must only be turned up far enough for the ear to register an overload.

If the loudspeaker chassis become damaged after a long period of overload, this can be detected beyond any doubt by PIEGA service technicians. In these cases, PIEGA is not liable for any warranty claims.

Note:

Excessively loud music can damage your health.
Listen to music at an acceptable volume level for the sake of your health.

Daily Use

From development to production, right down to quality testing, PIEGA only uses materials and components of the highest quality. Your new PIEGA loudspeakers are provided with a polished aluminum surface. Although this material is not very sensitive, it should be treated with due care.

Care instructions:

Clean the surfaces of the PIEGA loudspeakers with a soft, fluff-free cloth.

If necessary use a soft cloth sprayed with a little mild window cleaner.

Never use solvents to clean your PIEGA loudspeakers.

Never use abrasive detergents or any agents with abrasive ingredients.

Warnings:

Do not remove the front cover.

To avoid damage, take great care when children are close to the loudspeakers.

Attention:

On no account touch the tweeter foil of your loudspeaker.



Warranty Conditions

The warranty is limited to six years on our loudspeakers and three years on our electronics in accordance with the conditions stated below. Read through the service and warranty conditions carefully, especially the warnings concerning the purchase of PIEGA loudspeakers from unauthorized dealers.

Warranty

1. Every Piega device leaves the factory in perfect condition. If any manufacturing and/or material defects are found during normal use of the device, we warrant to repair the device with free parts and labor during the first six years from the date of purchase.
2. The registration card for the device must be sent to Piega within six weeks of purchase, or registered online via the Internet at www.piega.ch/en/service/warranty.htm.
3. The product must be purchased from an authorized Piega dealer.
4. The warranty will not be applicable if any repair is carried out by a person or a workshop that is not authorized to do this by Piega.
5. If it is necessary for a device or part of it to be sent to Piega or an approved Piega workshop, the sender is responsible for paying all transport costs in advance. The original packaging must be used for sending the complete device.
6. The warranty will not be applicable if the serial number of the device has been modified, removed or made illegible. It will also not apply if the device is not connected properly or not treated with due care. The warranty will also not be applicable if the device was modified or repaired in any way that in our view has altered the correct functioning of the device.
7. Piega shall not be liable for the consequences of any damage.

PIEGA Loudspeaker products from unauthorized dealers

The official PIEGA warranty becomes invalid if a PIEGA loudspeaker product was purchased from an unauthorized dealer and is therefore a gray market product, or if the original serial number has been intentionally removed, replaced or made illegible. Should you have any doubt that the dealer you have selected is an officially authorized PIEGA dealer, we recommend that you contact us or the PIEGA sales organization in your country without fail. Please note the PIEGA sales policy statement at www.piega.ch

PIEGA SA
Bahnhofstrasse 29
CH-8810 Horgen
Telephone +41 44 725 90 42
Fax +41 44 725 91 92
mail@piega.ch
www.piega.ch

Information for Exports

PIEGA SA
Bahnhofstrasse 29
CH-8810 Horgen
Telephone +41 44 725 90 02
Fax +41 44 725 91 92
mail@piega.ch
www.piega.ch

Published Summer 2010
Subject to modifications, in particular
technical modifications and errors